

# Drill rigs — Safety

The European Standard EN 791:1995 has the status of a  
British Standard

ICS 91.220

## Committees responsible for this British Standard

The preparation of this British Standard was entrusted by Technical Committee B/513, Construction equipment and plant, and site safety, to Subcommittee B/513/2, Drilling, piling and tunnelling — safety upon which the following bodies were represented:

Association of British Mining Equipment Companies  
 British Compressed Air Society  
 British Drilling Association  
 British Tunnelling Society  
 Federation of Civil Engineering Contractors  
 Federation of Manufacturers of Construction Equipment and Cranes  
 Federation of Piling Specialists  
 Health and Safety Executive  
 Institute of Sound and Vibration Research  
 Institution of Civil Engineers  
 Institution of Mining and Metallurgy  
 Pipe Jacking Association

This British Standard, having been prepared under the direction of the Sector Board for Building and Civil Engineering, was published under the authority of the Standards Board and comes into effect on 15 June 1996

© BSI 02-1999

The following BSI references relate to the work on this standard:  
 Committee reference B/513/2  
 Draft for comment 92/16005 DC

ISBN 0 580 25547 6

### Amendments issued since publication

Amd. No.	Date	Comments

---

# Contents

	Page
Committees responsible	Inside front cover
National foreword	ii
Foreword	2
Text of EN 791	5
List of references	Inside back cover

---

## National foreword

This British Standard has been prepared by Subcommittee B/513/2 and is the English language version of EN 791:1995 *Drill rigs — Safety*, published by the European Committee for Standardization (CEN). It is one of a number of British Standards implementing European Standards on machinery safety matters, in the development of which the United Kingdom has played an active part.

This British Standard covers the essential safety requirements in the Machinery Directive (89/392/EEC) and the Amending Directive (91/368/EEC).

### Cross-references

Publication referred to	Corresponding British Standard
EN 3:1975	BS 5423:1987 <i>Specification for portable fire extinguishers</i> BS EN 292 <i>Safety of machinery. Basic concepts, general principles for design</i>
EN 292-1:1991	Part 1:1991 <i>Basic terminology, methodology</i>
EN 292-2:1991	Part 2:1991 <i>Technical principles and specifications</i>
EN 294:1992	BS EN 294:1992 <i>Safety of machinery. Safety distances to prevent danger zones being reached by the upper limbs</i>
EN 418:1992	BS EN 418:1992 <i>Safety of machinery. Emergency stop equipment, functional aspects. Principles for design</i>
ENV 1070:1993	DD ENV 1070:1993 <i>Safety of machinery. Terminology</i>
prEN 563 <sup>a</sup>	BS EN 563:1994 <i>Safety of machinery — Temperatures of touchable surfaces — Ergonomics data to establish temperature limit values for hot surfaces</i> BS 6912 <i>Safety of earth-moving machinery</i>
EN 22860:1985	Part 5:1992 <i>Recommendations for minimum access dimensions</i>
EN 23164:1985	Part 7:1992 <i>Specification for laboratory evaluations of roll-over and falling object protective structures: the deflection-limiting volume for earth-moving machinery</i>
EN 23411:1988	BS 5538:1983 <i>Specification for minimum operator space envelope for earth-moving machinery</i>
EN 50081-2:1993	BS EN 50081 <i>Electromagnetic compatibility. Generic emission standard</i> Part 2:1994 <i>Industrial environment</i>
EN 50082-2:1994	BS EN 50082 <i>Electromagnetic compatibility. Generic immunity standard</i> Part 2:1995 <i>Industrial environment</i>
EN 60204-1:1992	BS EN 60204 <i>Safety of machinery. Electrical equipment of machines</i> Part 1:1993 <i>Specification for general requirements</i>
ISO 2867:1994 <sup>b</sup>	BS 6912 <i>Safety of earth-moving machinery</i> Part 15:1995 <i>Specification for access systems</i>
ISO 3449:1992	Part 6:1992 <i>Specification for falling-object protective structures on earth-moving machinery: Laboratory tests and performance requirements</i>
ISO 3450:1985	BS 6824:1987 <i>Specification for performance and test of braking systems for wheeled earth-moving machinery</i>
ISO 3457:1986	BS EN ISO 3457:1995 <i>Specification for guards and shields for earth-moving machinery</i>
ISO 3471:1994 <sup>c</sup>	BS 6912 <i>Safety of earth-moving machinery</i>

	<i>Part 14:1995 Specification for laboratory tests and performance requirements of roll-over protective structures</i>
ISO 3795:1989	BS AU 169a:1992 <i>Method for determination of burning behaviour of interior materials for road vehicles, and tractors and machinery for agriculture and forestry</i>
ISO 6682:1986	BS EN ISO 6682:1995 <i>Earth-moving machinery. Zones of comfort and reach for controls</i> BS 6912 <i>Safety of earth-moving machinery</i>
ISO 10570:1992	Part 8:1992 <i>Specification for performance requirements of an articulated frame locking device</i>
IEC 651:1979	BS EN 60651:1994 <i>Specification for sound level meters</i>
IEC 804:1985	BS EN 60804:1994 <i>Specification for integrating-averaging sound level meters</i>

<sup>a</sup> Now published as EN 563:1994.

<sup>b</sup> ISO 2867:1989 has been withdrawn and has been replaced by ISO 2867:1994.

<sup>c</sup> ISO 3471-1:1986 has been withdrawn and has been replaced by ISO 3471:1994.

A British Standard does not purport to include all the necessary provisions of a contract. Users of British Standards are responsible for their correct application.

**Compliance with a British Standard does not of itself confer immunity from legal obligations.**

### Summary of pages

This document comprises a front cover, an inside front cover, pages i to iv, the EN title page, pages 2 to 48, an inside back cover and a back cover.

This standard has been updated (see copyright date) and may have had amendments incorporated. This will be indicated in the amendment table on the inside front cover.



---

ICS 91.220

Descriptors: Drilling equipments, percussion drilling, rotary drilling, safety of machines, dangerous machines, hazards, safety measures, operating stations, control devices, brakes, safety devices, stability, fire protection, engine noise, vibration, marking, name plates, technical notices

English version

## Drill rigs — Safety

Appareils de forage — Sécurité

Bohrgeräte — Sicherheit

This European Standard was approved by CEN on 1995-07-01. CEN members are bound to comply with the CEN/CENELEC Internal Regulations which stipulate the conditions for giving this European Standard the status of a national standard without any alteration.

Up-to-date lists and bibliographical references concerning such national standards may be obtained on application to the Central Secretariat or to any CEN member.

This European Standard exists in three official versions (English, French, German). A version in any other language made by translation under the responsibility of a CEN member into its own language and notified to the Central Secretariat has the same status as the official versions.

CEN members are the national standards bodies of Austria, Belgium, Denmark, Finland, France, Germany, Greece, Iceland, Ireland, Italy, Luxembourg, Netherlands, Norway, Portugal, Spain, Sweden, Switzerland and United Kingdom.

# CEN

European Committee for Standardization  
Comité Européen de Normalisation  
Europäisches Komitee für Normung

**Central Secretariat: rue de Stassart 36, B-1050 Brussels**

## Foreword

This European Standard has been prepared by CEN/TC 151, Construction equipment and building material machines — Safety, of which the secretariat is held by DIN.

This European Standard has been prepared under a mandate given to CEN by the Commission of the European Communities and the European Free Trade Association, and supports the essential requirements of EC Directive(s).

This standard is a Type C-standard in the structure of A-/B-/C- standards as defined in EN 292.

The Annex A is normative and contains “Measurement of noise and vibration”, the Annex B is normative and contains “Instructions for the examination and checking of blocks, wire ropes and chains”, the Annex C is normative and contains “Brake test for drill rigs excluding truck and tractor mounted drill rigs”, the Annex D is normative and contains “Hazards related to operation modes of drill rigs”, the Annex E is informative and contains “Symbols and signs”, and the Annex F is informative and contains “Bibliography”.

This European Standard shall be given the status of a national standard, either by publication of an identical text or by endorsement, at the latest by May 1996, and conflicting national standards shall be withdrawn at the latest by May 1996.

According to the CEN/CENELEC Internal Regulations, the following countries are bound to implement this European Standard: Austria, Belgium, Denmark, Finland, France, Germany, Greece, Iceland, Ireland, Italy, Luxembourg, Netherlands, Norway, Portugal, Spain, Sweden, Switzerland, United Kingdom.

## Contents

	Page		Page
Foreword	2	5.1.6 Materials	9
0 Introduction	5	5.1.7 Handling of the drill rig and its parts	9
1 Scope	5	5.1.8 Access to operating positions and servicing points	10
2 Normative references	6	5.1.9 Isolation of energy sources	10
3 Definitions	7	5.2 Driving, tramming and operating position	10
4 List of hazards	8	5.2.1 General	10
5 Safety requirements and measures	9	5.2.2 Operator's position	10
5.1 General safety requirements	9	5.2.3 Underground drill rigs	11
5.1.1 Intended use of the drill rig	9	5.2.4 Visibility	11
5.1.2 Ergonomics	9	5.3 Controls, functions, systems	11
5.1.3 Hot and cold surfaces and sharp edges	9	5.3.1 General	11
5.1.4 Ventilating ports	9	5.3.2 Starting	11
5.1.5 Hoses, pipes and fittings under pressure	9	5.3.3 Stopping	11
		5.3.4 Failure of the power supply	11
		5.3.5 Failure in a control circuit	11
		5.4 Control devices	11
		5.4.1 General	11
		5.4.2 Emergency stop and safety devices	12
		5.4.3 Verification	12
		5.5 Stability	12
		5.5.1 General stability criteria	12
		5.5.2 Definitions for stability calculations	12
		5.5.3 Verification of stability	13
		5.5.4 Ground pressure, calculation for crawler mounted drill rigs	17
		5.6 Carrier brakes	17
		5.6.1 General	17
		5.6.2 General requirements for wheel mounted drill rigs	19
		5.6.3 Service braking system for wheel mounted drill rigs	19
		5.6.4 Secondary braking system for wheel mounted drill rigs	19
		5.6.5 Parking braking systems for wheel and crawler mounted drill rigs	19
		5.6.6 The service, secondary and parking braking systems on crawler mounted drill rigs	19
		5.6.7 Braking systems for “skid steer” wheel mounted drill rigs	20
		5.6.8 Verification	20
		5.7 Protection against moving parts	20
		5.7.1 General	20
		5.7.2 Transmission parts	20

	Page		Page
5.7.3	20	Moving parts involved in the working process	7
5.8	21	Electrical installations	Instructions for use — Instruction handbooks
5.8.1	21	Electric power installation	26
5.8.2	21	Battery installation	7.1
5.9	21	Hydraulic installations	Marking — Data plate
5.10	21	Pneumatic installations	7.2
5.11	21	Lighting	Indicators
5.11.1	21	Working light	7.2.1
5.11.2	22	Illumination when tramming	Information indicators
5.12	22	Fire protection	7.2.2
5.12.1	22	General	Warning signs for residual hazards
5.12.2	22	Fire extinguishers	7.3
5.12.3	22	Installation of fire extinguishers	Maintenance
5.13	22	Noise and vibration	7.4
5.13.1	22	General	Instruction handbooks for drill rigs
5.13.2	22	Noise	7.4.1
5.13.3	22	Vibration	General
5.14	22	Dust and gases	7.4.2
5.14.1	22	Dust suppression	Operator's instructions
5.14.2	23	Engines and engine exhausts	7.4.3
5.15	23	Draw-works, winches and ropes	Special safety instructions in the operator's instructions
5.15.1	23	General	7.4.4
5.15.2	23	Safety requirements	Maintenance instructions
5.15.3	24	Winches for operating a drill rig on slopes	7.4.5
5.16	24	Roller and leaf chains	Special safety instructions in the maintenance instruction
5.17	24	Masts, derricks, feed beams and working platforms	7.4.6
5.17.1	24	General	Spare parts list
5.17.2	24	Racking and working platforms	Annex A (normative) Measurement of noise and vibration
5.17.3	25	Personnel lift for operational work	30
5.17.4	25	Movable platforms for service, maintenance and repair	Annex B (normative) Instructions for the examination and checking of blocks, wire ropes and chains
5.17.5	25	Access	31
5.17.6	25	Escape systems	Annex C (normative) Brake test for drill rigs excluding truck and tractor mounted drill rigs
5.18	25	Special requirements for remotely controlled and automated drill rigs	31
5.18.1	25	Operating position	Annex D (normative) Hazards related to operation modes of drill rigs
5.18.2	25	Emergency stop	33
5.18.3	26	Control system	Annex E (informative) Symbols and signs
5.18.4	26	Fire protection	34
5.19	26	Warning devices	Annex F (informative) Bibliography
6	26	Verification of safety requirements/measures	47
			Figure 1 — Sweep radius
			8
			Figure 2 — Wheel mounted drill rig
			14
			Figure 3 — Tipping lines for wheel mounted carrier when tramming
			14
			Figure 4 — Crawler mounted drill rig
			14
			Figure 5 — A pair of support points form a tipping line
			15
			Figure 6 — Tipping lines of crawlers
			15
			Figure 7 — Stability angle
			16
			Figure 8 — Ground pressure
			18



## 0 Introduction

The extent to which hazards are covered is indicated in the scope of this standard.

In addition, machinery should comply as appropriate with EN 292 for hazards which are not covered by this standard.

Those hazards that are relevant for all mechanical, electrical, hydraulic, pneumatic and other equipment of machinery and that are dealt with in standards for common use are not covered by this standard.

Reference to pertinent standards of this kind is made where such standards are applicable and so far as is necessary.

## 1 Scope

**1.1** The general term “drill rig” covers several differing types of machines for use in the construction industry, water well drilling industry, mining and quarrying, for use above ground as well as underground and for tunnel construction. The differing tasks determine the choice of drilling method and type of machine. For this reason there are many possible ways to separate drill rigs into different groups, e.g. in accordance with:

- the task;
- the drilling method used;
- the cutting removal method;
- the type of construction work.

The methods used for drilling can be basically differentiated in percussive and rotary drilling principles.

Percussive drilling is a method by which the hole is produced by crushing the ground or rock at the bottom of the drill-hole by striking it with the drilling tool and removing the cuttings out of the borehole.

Rotary drilling is a method in which the drilling tool at the bottom of the borehole is rotated and at the same time, a feed force is applied by a feed system or drill collar. The ground or rock at the bottom of the borehole is crushed or cut by pressure, shear or tensile stress produced by the different drilling tools. The cuttings are periodically or continuously removed out of the bore hole.

Rotary percussive drilling is performed by a piston striking directly on the bit (down the hole hammer drills) or by percussive energy transmitted via a drill string to the bit. The piston is powered by either hydraulic fluid or compressed air.

At the same time the drill bit is rotated either continuously or intermittently.

The cuttings are continuously removed out of the borehole by a flushing medium, air or fluid which is carried to the drilling tool.

Typical examples of drill rigs covered by this standard are:

- cable tool drill rig;
- pile drill rigs;
- pile top drill rig;
- raise borer;
- reverse circulation drill rig;
- rotary and rotary percussive drill rig for underground drilling;
- rotary and rotary percussive drill rig for surface drilling;
- rotary drill rig with power swivel;
- rotary spindle rig;
- rotary drill rig for underground use.

A casing or a drilling fluid may be used to stabilize the bore hole.

Drill rigs are stationary during drilling. They may move from one place of work to another, under their own power. Self propelled drill rigs may include those mounted on lorries, wheeled chassis, tractors, crawlers, skid bases (pulled by winch). When drill rigs are mounted on lorries, tractors and trailers, or are wheeled based, transportation may be carried out at higher speeds and on public roads. When designing and constructing these units attention is drawn to regulations covering both the drill rig and traffic regulations.

The questions of safety and ergonomic criteria in this standard mainly refer to the principal work, e.g. when the machine is stationary and drilling. In many cases the driver is also the operator of the drill rig.

**1.2** This standard deals with the significant hazards pertinent to mechanized drill rigs, when used as intended and under the conditions foreseen by the manufacturer. It specifies requirements of safety concerning the design, construction, operation and maintenance. This standard applies to drill rigs for surface and underground drilling in the tunnelling, mining, construction and water well drilling industries. Casing units are also covered by this standard.

If the base of a drill rig consists of an excavator, crane, etc. it shall be covered by its own standards to the extent the requirements of this standard are not applicable.

**NOTE 1** If a drill rig operates with attachments other than those for drilling according to this standard, e.g. pile driving, the safety standards applying to such machines shall also be complied with.

For drill rigs to be used in an explosive atmosphere (coal mining etc.) the relevant standards apply additionally.

NOTE 2 CEN/TC 196 is preparing complementary standards for machines to be used in explosive atmospheres.

Oil and gas industry drill rigs are not covered by this standard.

## 2 Normative references

This European Standard incorporates, by dated or undated references, provisions from other publications. These normative references are cited at the appropriate places in the text and the publications are listed hereafter. For dated references, subsequent amendments to or revisions of any of these publications apply to this European Standard only when incorporated in it by amendment or revision. For undated references the latest edition of the publication referred to applies.

EN 3:1975, *Portable fire extinguishers*.

EN 292-1:1991, *Safety of machinery — Basic concepts, general principles for design — Part 1: Basic terminology, methodology*.

EN 292-2:1991, *Safety of machinery — Basic concepts, general principles for design — Part 2: Technical principles and specifications*.

EN 294:1992, *Safety of machinery — Safety distance to prevent danger zones being reached by the upper limbs*.

EN 418:1992, *Safety of machinery — Emergency stop equipment, functional aspects — Principles for design*.

prEN 563, *Safety of machinery — Temperatures of touchable surfaces — Ergonomic data to establish temperature limit values for hot surfaces*.

prEN 953, *Safety of machinery — General requirements for the design and construction of guards (fixed, movable)*.

prEN 954-1, *Safety of machinery — Safety related parts of control systems — Part 1: General principles for design*.

prEN 982, *Safety requirements for fluid power systems and components — Hydraulics*.

prEN 983, *Safety requirements for fluid power systems and components — Pneumatics*.

prEN 1037, *Safety of machinery — Isolation and energy dissipation — Prevention of unexpected start-up*.

ENV 1070:1993, *Safety of machinery — Terminology*.

EN 22860:1985, *Earth-moving machinery — Minimum access dimensions*.

EN 23164:1985, *Earth-moving machinery — Laboratory evaluations of roll-over and falling-object protective structures — Specifications for the deflection-limiting volume*.

EN 23411:1988, *Earth-moving machinery — Human physical dimensions of operators and minimum operator space envelope*.

EN 50081-2:1993, *Electromagnetic compatibility — Generic emission standard — Part 2: Industrial environment*.

EN 50082-2:1994, *Electromagnetic compatibility — Generic immunity standard — Part 2: Industrial environment*.

EN 60204-1:1992, *Electrical equipment of industrial machines — Part 1: General requirements*.

ISO 2631-1:1985, *Evaluation of human exposure to whole-body vibration — Part 1: General requirements*.

ISO 2867:1989, *Earth-moving machinery — Access systems*.

ISO 3449:1992, *Earth-moving machinery — Falling-object protective structures — Laboratory tests and performance requirements*.

ISO 3450:1985, *Earth-moving machinery — Wheeled machines — Performance requirements and test procedures for braking systems*.

ISO 3457:1986, *Earth-moving machinery — Guards and shields — Definitions and specifications*.

ISO 3471-1:1986, *Earth-moving machinery — Roll-over protective structures — Laboratory tests and performance requirements — Part 1: Crawler, wheel loaders and tractors, backhoe loaders, graders, tractor scrapers, articulated steer dumpers*.

ISO 3795:1989, *Road vehicles and tractors and machinery for agriculture and forestry — Determination of burning behaviour of interior materials*.

ISO 4302:1981, *Cranes — Wind load assessment*.

ISO 4309:1990, *Cranes — Wire ropes — Code of practice for examination and discard*.

ISO 4872:1978, *Acoustics — Measurement of airborne noise emitted by construction equipment intended for outdoor use — Method for checking compliance with noise limits*.

ISO 6682:1986, *Earth-moving machinery — Zones of comfort and reach for controls*.

ISO 10570:1992, *Earth-moving machinery — Articulated frame lock — Performance requirements*.

ISO/DIS 11201:1993, *Acoustics — Noise emitted by machinery and equipment — Measurement of emission sound pressure levels at the work-station and at other specified positions — Engineering method in an essentially free field over a reflecting plane.*

IEC 651:1979, *Sound level meters.*

IEC 804:1985, *Integrating-averaging sound level meters.*

### 3 Definitions

For the purpose of this standard, the definitions of ENV 1070:1993 apply. Additional definitions, specifically needed for drill rigs, are added below.

#### 3.1

##### **danger zone**

any zone within and/or around a drill rig in which a person is exposed to risk of injury or damage to health

NOTE For a drill rig this means the area in which a person can be reached by an operational movement of the drill rig, its working devices, its auxiliary equipment or swinging or falling equipment.

#### 3.2

##### **working area**

an area near a machine in which its tools are moved in order to carry out work

#### 3.3

##### **exposed person**

a person wholly or partially in the danger zone

#### 3.4

##### **operator**

a person operating the drill rig while drilling. He may also be the driver of the rig

#### 3.5

##### **driver**

a person responsible for the movement of the drill rig

NOTE The driver may be transported on the drill rig, may be on foot (pedestrian driver) or he may control the drill rig by remote control.

#### 3.6

##### **hook load**

the actual load carried by the hook of the bottom block, including the weight of the bottom block and of the running ropes

NOTE A distinction shall be made between the normal operating case and the exceptional operating case as defined in 3.7 and 3.8.

#### 3.7

##### **normal operating case**

operating conditions that are normal or usual such as those occurring mainly during the sinking and clearing out of bore holes

NOTE The maximum permissible hook load under those conditions is designated as the normal hook load

#### 3.8

##### **exceptional operating case**

operating conditions, which do not arise frequently or are of limited duration and during which, the normal hook load may be exceeded. The maximum permissible hook load under these conditions is designated as the exceptional hook load

NOTE Examples are fishing jobs and certain casing operations.

#### 3.9

##### **stability angle**

the angle between the vertical plane, passing through the tipping line and the plane passing through the centre of gravity, displaced as defined in 5.5.2 and the tipping line. The stability angle thus defined the tilt angle to overturning

#### 3.10

##### **tipping lines**

a) For drill rigs, crawler and wheel mounted:

- 1) in the direction of travel, the lines connecting the lowest support points of contact of the idlers, rollers or the drives of the tracks or the front wheels, see Figure 2 to Figure 6;
- 2) in sideward direction (perpendicular to the direction of travel), the lines passing through the centres of the support contact areas on each side of the chassis, see Figure 2 to Figure 6.

b) For drill rigs on support legs:

The lines connecting the centres of the support legs/jacks on each side of the chassis, see Figure 2 and Figure 5.

#### 3.11

##### **total vertical resultant force**

the sum of the total weight force of the drill rig and all other working forces in the vertical direction

NOTE Resultant horizontal forces (wind forces etc.) have an influence only on the position of the total vertical resultant force.

#### 3.12

##### **tramming**

short movements of a drill rig in drilling condition on site

### 3.13 sweep radius

a special term for drill rigs with booms, being the outer radius,  $R$ , of the turning circle for a drill rig in tramming, see Figure 1

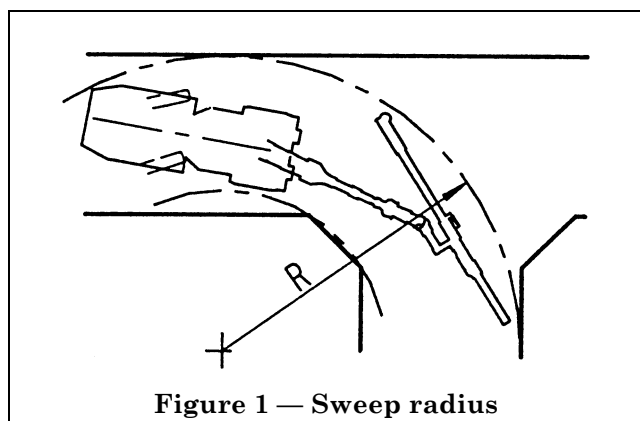

Figure 1 — Sweep radius

### 3.14 safety factor of rope

the ratio between the minimum breaking load of a rope guaranteed by the manufacturer, and maximum pulling force of a rope on the first layer of a winch

### 3.15 examination

a periodic thorough visual inspection by a competent person to determine faults or damage, of all components important to safety, and functional tests including all necessary measurements

### 3.16 check

a frequent inspection of components by the operator or the maintenance personnel to detect obvious damages or faults, and to determine, by means of spot checks, their ability to function normally

### 3.17 personnel lift for operational work

a lift used only for personnel transport and consisting of a guided platform on the mast

NOTE The vertical movement is commonly winch operated.

### 3.18 movable platforms for maintenance and repair

a platform attached to parts of the drilling equipment, e.g. the drill head, which can be moved along the drill mast. The attachment can be temporary or permanent

NOTE Personnel and material can be moved on this platform and personnel can work from it.

## 4 List of hazards

This clause contains all hazards, as far as they are treated in this standard, identified by risk assessments significant for drill rigs and which require action to eliminate or reduce risk.

### 4.1 Mechanical hazards

	Clause
Drawing in or trapping	5.4.2.2; 7.4.3; 7.4.5
High pressure fluid ejection	5.1.5
Ejection of parts	5.2.2; 5.3.4; 5.7.4
Falling objects	5.2.2; 5.2.3
Loss of stability	5.5; 5.15
Slip, trip and fall	5.1.8; 5.17
<b>4.2 Electrical hazards</b>	
Electrical contact directly or indirectly	5.1.9; 5.8
<b>4.3 Thermal hazards</b>	
Hot and cold surfaces	5.1.3
<b>4.4 Hazards generated by noise</b>	
	5.2.2; 5.13.1; 5.13.2
<b>4.5 Hazards generated by vibrations</b>	
	5.13.3
<b>4.6 Hazards generated by materials and substances processed, used or exhausted</b>	
Harmful dust and exhaust emissions	5.14
Ejection of material from auger	7.4.2
Fire risk	5.12
<b>4.7 Hazards generated by neglecting ergonomic principles</b>	
	5.1.2; 5.2.1; 5.2.2; 5.4.1
Lighting	5.11
Visibility	5.2.4
<b>4.8 Hazards caused by failure of energy supply, breaking down of machinery parts and other functional disorders</b>	
Failure of energy supply	5.3.4; 5.1.9
Failure of control systems	5.3.5

Unexpected loss of machine stability	5.2.1; 5.15.3
Failures of brakes	5.6
Failures of roller and leaf chains	5.16
<b>4.9 Hazards caused by missing and incorrectly positioned safety-related measures and means</b>	
All kinds of guards	5.1.3; 5.1.4; 5.1.5; 5.2.2; 5.2.3; 5.4.2.3; 5.7.1; 5.7.2; 5.7.3
Safety-related devices	5.17.1; 5.17.2; 5.17.3; 5.17.4; 5.17.5; 5.17.6
Start and stop devices	5.3.1; 5.3.2; 5.3.3; 5.3.4; 5.3.5
Safety signs and tags	5.19; 7.2; Annex E
All kinds of information	5.7.3.4; 7
Energy supply disconnecting devices	5.1.9; 5.3.1
Emergency stops and safety devices	5.3.3; 5.4.2
Feeding and take off means for workpieces	5.7.3
See also Annex D for hazards in the various modes of operation of the drill rigs.	

## 5 Safety requirements and measures

### 5.1 General safety requirements

#### 5.1.1 Intended use of the drill rig

When developing and designing a drill rig its intended use shall be considered as well as uses which can be reasonably expected in accordance with clause 5 of EN 292-1:1991.

#### 5.1.2 Ergonomics

The drill rig shall be designed according to ergonomic principles to avoid fatigue and stress on the operator. Consideration shall be given to the fact that operators may wear heavy gloves, footwear and other personal protection equipment. For guidance, see EN 23411:1988 and ISO 6682:1986.

#### 5.1.3 Hot and cold surfaces and sharp edges

Where there is a risk of human contact with hot or cold surfaces, such surfaces shall be protected by guards or covers in accordance with 4.8 of ISO 3457:1986 and prEN 563. Surfaces and edges shall fulfil the requirements of 3.1 of EN 292-2:1991.

#### 5.1.4 Ventilating ports

The mechanical ventilation and the cooling ports shall be provided with grills or similar devices to prevent fingers and limbs from reaching the moving components, in accordance with EN 294:1992.

#### 5.1.5 Hoses, pipes and fittings under pressure

Pipes, hoses and fittings shall be able to withstand the stresses from the pressure. The hoses shall be marked with the rated working pressure. The requirements of prEN 982 and prEN 983 shall be complied with. Where there is a risk that a rupture of a hose or pipe at the operator's position could cause hazard to the operator, the hoses and pipes in this area shall be provided with protective guards in accordance with 4.9 of ISO 3457:1986.

Flushing hoses, such as air, grout and mud hoses, shall be secured against freeing themselves, by means of adequate restraints.

#### 5.1.6 Materials

Materials used in drill rigs shall be chosen so that they do not cause any danger to an exposed person's health or safety. The materials shall be suitable for the foreseen ambient temperatures. The manufacturer shall indicate in the operator's instructions the temperature range for which the drill rig is designed.

#### 5.1.7 Handling of the drill rig and its parts

There shall be defined lifting points or devices for lifting the whole drill rig or parts of it. They may also be used for holding and securing the machine during transport. Lifting points shall be clearly marked.

On articulated carriers there shall be a mechanical locking device for locking the articulated joint during lifting and transport. The articulated frame lock shall be as specified in ISO 10570:1992.

Components and parts of a drill rig which require to be manually handled shall be designed in such a way as to allow safe manual handling.

If the weight and/or a form of components prevent safe manual handling, they shall be so designed that lifting appliances can be safely used.

#### **5.1.8 Access to operating positions and servicing points**

Stairs, ladders, catwalks, foot steps, hand holds, support handles, guard rails etc. shall be provided to allow access in safety to all areas for normal operation, adjustment and maintenance. For guidance see ISO 2867:1989.

When doors, windows and flaps are designed to open and close freely, it shall be possible to secure them in both closed and open positions.

#### **5.1.9 Isolation of energy sources**

Drill rigs supplied with external energy shall be fitted with means to isolate them from all energy sources. Such devices shall be clearly identified and it shall be possible to lock them if reconnection could endanger exposed persons. The requirements in prEN 1037 and 5.3 of EN 60204-1:1992 shall be complied with.

After the energy is shut off, it shall be possible to dissipate any energy remaining or stored in the circuits of the drill rig without risk to exposed persons.

As an exception from the above requirements, certain circuits may remain connected to their energy sources, e.g. to hold parts in position, to protect information, to provide interior lighting.

### **5.2 Driving, tramming and operating position**

#### **5.2.1 General**

The driving, tramming and operating position(s) shall be designed and constructed so that all manoeuvres necessary for the driving and operation of the drill rig can be performed by the operator from the driving and/or operating position(s) without risk to himself or to other persons in the vicinity of the rig. Required space, leg room etc. shall be in accordance with EN 23411:1988 and ISO 6682:1986.

For requirements regarding the driver's position on truck and tractor mounted drill rigs, see appropriate standards.

For the tramming of a drill rig, where there is a risk of roll-over, an alternative driver's position or a roll-over protective structure (ROPS) in accordance with ISO 3471-1:1986 shall be provided, so that the driver can manoeuvre the drill rig without risk to himself. For some special applications remote control shall be provided.

#### **5.2.2 Operator's position**

Drill rigs shall be provided with a cab to protect the operator against noise, dust and adverse weather conditions. There may however be types of drill rigs or operating conditions where it would not be appropriate or possible to provide a cab.

Drill rigs shall be designed for and fitted with falling object protective structure (FOPS) if they are specified for use in applications where there is a risk of rock fall. The FOPS shall comply with level II of ISO 3449:1992.

NOTE 1 The scope of ISO 3449:1992 excludes drill rigs. However for drill rigs the requirements of ISO 3449:1992 are equally applicable as for earth-moving equipment.

Pile drill rigs shall in all cases be fitted with a protective roof. It shall meet the requirements of level I of ISO 3449:1992.

Consideration shall also be given to protection against horizontally ejected objects, e.g. in the case of auger and pile drilling.

The cab shall provide the following:

- ventilation with adequate dust filtration where necessary and where applicable, heating and/or cooling;

NOTE 2 For this requirement no verification is given.

- protection against noise; the sound pressure level shall not exceed 85 dB(A) within the cab when tested in accordance with Annex A;
- isolation against vibration of the floor, see 5.13.3;
- a means of rapid escape from the cab;
- an emergency exit, e.g. in the form of knock-out windows or knock-out panels, on a different side of the cab from that where the normal exit is situated or provision of tools for breaking the window;
- a seat, unless the operator has to work in a standing position. The seat shall provide the operator with a comfortable and stable working position and shall be easily adaptable to operators of different weight and height. The seat shall be designed to reduce vibrations transmitted to the operator to the lowest level that can be reasonably achieved;
- a windscreen cleaning device.

Transparent panels of doors and windows shall be made of laminated safety glass or equivalent material. The material of the interior of the cab shall be in accordance with the requirements of 5.12.1.

If there is a risk of falling objects, drill rigs without a cab shall be fitted with a protective structure fulfilling the requirements of 5.2.2 or an alternative operator's position, giving a safe working condition.

### 5.2.3 *Underground drill rigs*

When a drill rig for underground use is equipped with a boom mounted working platform intended for use in an area where there is risk of rock fall, the person(s) on the platform shall have adequate protection. A suitably designed protective structure, FOPS, as specified in 5.2.2 shall be provided over part of the platform taking into account the various functions to be performed from it.

The above requirements of FOPS shall be verified by testing the protective structure, the platform and the boom in a position that the energy of the falling object is absorbed by the whole construction.

### 5.2.4 *Visibility*

Visibility from the driver's and/or operator's position shall be such that when drilling or tramming the driver or operator can operate the drill rig without causing danger to himself or other persons. Where necessary, optical aids or other means shall be provided.

## 5.3 *Controls, functions, systems*

### 5.3.1 *General*

For control functions in electric, hydraulic and pneumatic systems see clauses 7, 9, 11, and 13 of EN 60204-1:1992, prEN 982, prEN 983 and for safety related parts see prEN 954-1.

### 5.3.2 *Starting*

Starting of the drill rig's main power source shall only be possible by an intentional actuation of the starting control device. This shall also apply after a stop from whatever cause.

Unauthorized starting shall be prevented by the provision of suitable safeguards, e.g. lockable cab, lockable starting switch or lockable electric isolator switch.

If the drill rig has several starting controls they shall be interlocked so that starting can only be carried out from one of the starting controls.

On a pneumatically powered drill rig a main line valve shall be provided on the rig, which either connects the drill rig to the air supply or in the closed position shuts off the air supply and releases the air pressure in the rig system.

### 5.3.3 *Stopping*

#### 5.3.3.1 *Normal stopping*

The drill rig shall be fitted with a stopping device by which drilling is brought safely to a complete stop.

#### 5.3.3.2 *Emergency stop*

In order that an actual or impending danger be averted quickly, emergency stops shall be provided. They shall stop all dangerous movements as quickly as possible to prevent a dangerous situation developing without creating an additional hazard. At every operating or driving position there shall be an emergency stop, see 5.4.2.1.

NOTE For a truck or tractor mounted drill rig this requirement does not apply to the driver's position.

An emergency stop with local effect shall stop a specific and limited function, e.g. rotation and feed, see 5.4.2.2.

#### 5.3.4 *Failure of the power supply*

An interruption of the power supply and a re-establishment after an interruption shall not lead to a dangerous situation in particular:

- it shall only be possible to restart a drill rig by an intentional action;
- the drill rig shall not be prevented from stopping if the stop command has been given;
- no part of the machine or a tool shall fall or be ejected;
- stopping, automatic or manual, of moving parts shall be unimpeded;
- guards and other protective devices shall remain effective.

A power failure or a hydraulic or pneumatic pressure drop shall not cause any dangerous movements or actions. Such failures shall not stop the emergency stop systems from functioning.

#### 5.3.5 *Failure in a control circuit*

A failure in the control circuit logic or in a control circuit shall not lead to a dangerous situation. The same safety requirements as stated in 5.3.4 shall be fulfilled.

## 5.4 *Control devices*

### 5.4.1 *General*

Control devices shall be marked without ambiguity in accordance with relevant standards and positioned for safe, quick and comfortable operation. For guidance see 3.6.6 of EN 292-2:1991 and Annex E.

Control devices shall be designed so that their movement is consistent with their effect.

All controls, other than those which control continuous operations e.g. drilling and casing operations, shall be of hold-to-run type.

Control devices shall:

- when they are of primary importance, be within comfortable reach;

- when they are of secondary importance, be within normal reach;
- where possible, be located outside the danger zone.

NOTE 1 For definition of comfort and reach, see ISO 6682:1986.

Where there is more than one operator's position, the drill rig shall be provided with a mode selector to intentionally select the control position which shall be used.

NOTE 2 This does not apply to any emergency stops or safety devices.

#### 5.4.2 Emergency stop and safety devices

##### 5.4.2.1 Emergency stop devices

The emergency stop devices shall be in accordance with EN 418:1992 and be placed within easy reach of the operator. See also 5.3.3.2.

The emergency stop shall, after actuation, remain engaged until manually reset. This manual resetting shall not start the machine but only permit restarting by the normal starting procedures.

##### 5.4.2.2 Safety device for stopping of rotation and feed

Drill rigs with a feed beam, where there is a risk that personnel can be caught and injured by the rotating member, shall be equipped with additional trip devices in the immediate area of the rotating drill string accessible to personnel. The trip devices shall be installed and equipped so that they will be automatically actuated in an emergency situation by the body or part of the body without any delay or difficulty. The trip device actuators shall be clearly marked. The trip device shall fulfil the requirements of 5.3.3.2.

NOTE 1 For examples of trip devices, see 3.23.5 of EN 292-1:1991.

If the drill rig is equipped with a mechanical drill rod/pipe handling system, a trip device on the free side of the drill rod/pipe is sufficient.

See also 5.7.3.3.

When actuating the trip device any residual energy in the system shall be contained or released so as not to cause any dangerous movements.

The trip device shall after actuation remain engaged until manually reset. This manual resetting shall not start the machine but only permit resetting by the normal starting procedures.

If such a trip device is not feasible, due to operational reasons, the danger zone shall be a forbidden access area when drilling and performing other hazardous operations. The forbidden access area shall be provided with "No Access" signs, see Annex E. See also 7.4.3.

NOTE 2 This safety device can have the same function as the emergency stop.

##### 5.4.2.3 Accidental actuation of controls

A safeguard preventing accidental actuation of the controls shall be fitted on control panels when such actuation can cause a hazard.

#### 5.4.3 Verification

All emergency stops and safety devices shall be tested for their proper function and a certificate shall be provided by the manufacturer.

#### 5.5 Stability

##### 5.5.1 General stability criteria

Drill rigs shall be so designed and constructed that they are sufficiently stable under the intended operating conditions, e.g. transport, tramming, parking and drilling and that there is no risk of overturning and falling. The stability shall be verified by calculation.

The following stability criteria and calculations refer to mobile and stationary drill rigs but are not applicable to drill rigs fixed to the ground or a foundation. For those drill rigs the moments from weights and forces shall be taken into account when calculating and designing the anchoring of the drill rig.

The stability angles,  $\alpha$ , as defined in 3.9 and 5.5.2 shall not be less than 10° in any directions when tramming and be not less than 5° under any other conditions.

NOTE The stability angle of 10° includes also a margin for the effects of the dynamic forces from acceleration and braking of the total drill rig.

When the drill rig is intended to work, tram or be parked on a plane deviating from the horizontal, the verification of stability shall include the maximum allowed slope angle under the most unfavourable conditions as specified and stated in the operator's instructions. The stability angle shall comply with the above mentioned limits, i.e. the safety margin of 10° and 5° respectively shall be added to the specified operational slope angle.

Instructions on stability and other essential restrictions of use which are of immediate importance shall be given on signs clearly visible at the driver's and operator's position, e.g. maximum allowed gradient angle for slopes when tramming or drilling.

Detailed instructions regarding the restrictions and special measures to be taken when drilling, tramming or parking shall be given in the operator's instructions, see 7.4.2.

##### 5.5.2 Definitions for stability calculations

The following factors and symbols shall be used to calculate the stability:

$G_t$  is the total weight of the drill rig including all equipment;

$X_t$	is the abscissa of the total centre of gravity referred to the tipping line;
$Y_t$	is the ordinate of the total centre of gravity referred to the tipping line
$\alpha_s$	is the static stability angle ( $\alpha_s = \arctan X_t/Y_t$ );
$M_w$	is the overturning moment of wind forces;
$M_a$	is the overturning moment of centrifugal forces;
$M_f$	is the overturning moment of other working forces;
$M_r$	= $M_w + M_a + M_f$ , i.e. the total overturning moment;
$M_s$	= $G_t \times X_t$ , i.e. the total stabilizing moment;
$\delta_x$	= $M_r/G_t$ , i.e. the apparent horizontal displacement of the centre of gravity, equivalent to the effect of the overturning moments;
$\alpha_d$	is the dynamic stability angle, i.e. $\alpha_d = \arctan (X_t - \Delta_x)/Y_t$ .

NOTE Tipping lines are defined in 3.10 and also shown in Figure 2 to Figure 6. The stability angles are illustrated in Figure 7.

### 5.5.3 Verification of stability

#### 5.5.3.1 General

The stability shall be verified by calculations based on operating conditions stated in 5.5.3.6 and factors according to 5.5.3.2 to 5.5.3.5 influencing the stability.

Weights and positions of centres of gravity of single parts of the drill rig including the base machine, which have a significant effect on the stability and which are input data for the stability calculation, shall be verified by calculation and/or weighing.

The calculations shall be based on the drill rig standing on a firm plane with a mast inclination as specified and stated in the operator's instructions and for the tipping line giving the lowest stability.

#### 5.5.3.2 Centre of gravity

The position of the total centre of gravity ( $X_t$ ;  $Y_t$ ) and the total weight,  $G_t$ , shall be measured by testing or calculated using the centres of gravity and weights of all parts of the drill rig.

In the case when a single main part is movable, the calculation shall be based on the position giving the condition of lowest stability, e.g. the rotary drive in its highest position, drill mast positioned as far out as possible and having its greatest forward inclination as specified in the operator's instructions.

For drill rigs with oscillating tracks the displacement of the centre of gravity of the drill rig at the limits of the oscillating movements shall be taken into account in the stability calculations.

NOTE The final tipping lines remain the same as defined in 3.10.

#### 5.5.3.3 Dynamic forces

For drill rigs having a turnable superstructure, the centrifugal force which acts on the centre of gravity of the rotating masses, shall be taken into account in the calculation of stability.

#### 5.5.3.4 Wind force

The wind force shall be taken into account in the stability calculation. The wind force shall be assumed to act on the drill rig, including stacked drill rods and other equipment, adding to the overturning moment.

The wind forces shall be calculated according to clause 4 of ISO 4302:1981. The dynamic air pressure,  $q$ , from the wind shall be chosen as follows.

While drilling:

- $q = 250$  Pa (corresponding to a windspeed of 20 m/s).

Under parked and out of service conditions:

- $q = 800$  Pa (corresponding to 36 m/s) for areas up to 20 m above ground;
- $q = 1\ 100$  Pa (corresponding to 42 m/s) for areas between 20 m and 100 m above ground.

For off-shore applications:

- $q = 1\ 650$  Pa (corresponding to 49 m/s).

#### 5.5.3.5 Other working forces

Other working forces that can influence the stability shall be taken into account when calculating the stability e.g.:

- the winch force between drill mast and drilling tool in the bore hole. The drill string and tool shall not be regarded as a support when only a rope is being used for pulling up the drilling tool;
- in the case of drilling down, the drill string may be considered as a support;
- in the case of upwards drilling it shall be checked that the available feed forces do not make the rear part of the drill rig lift.

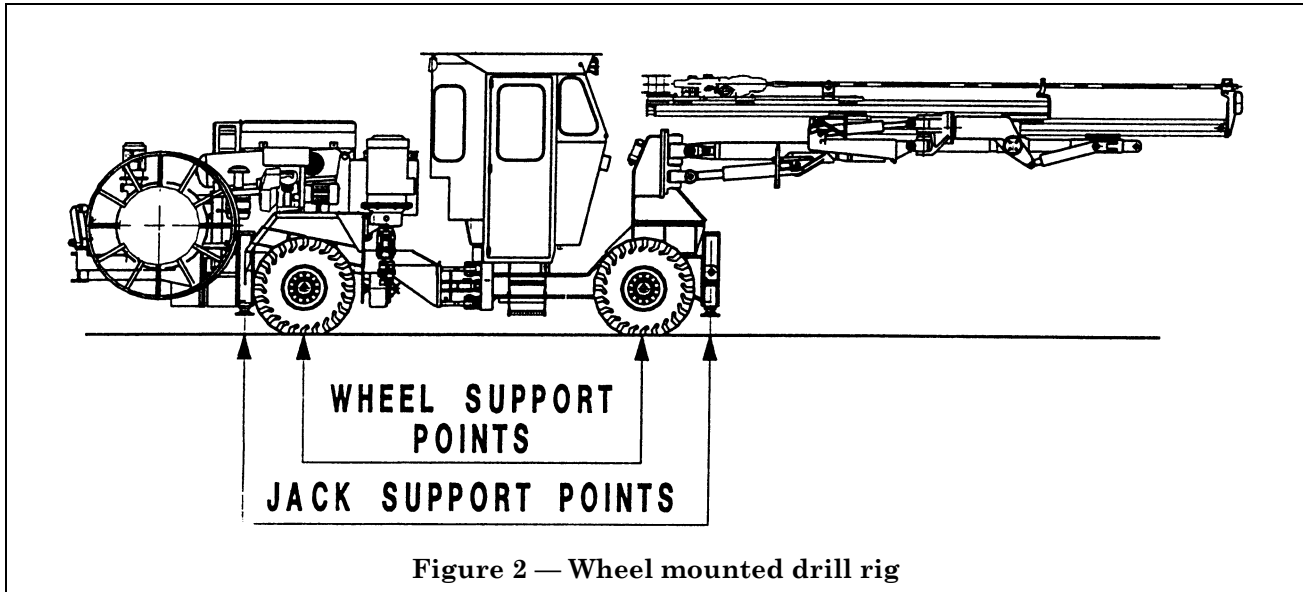
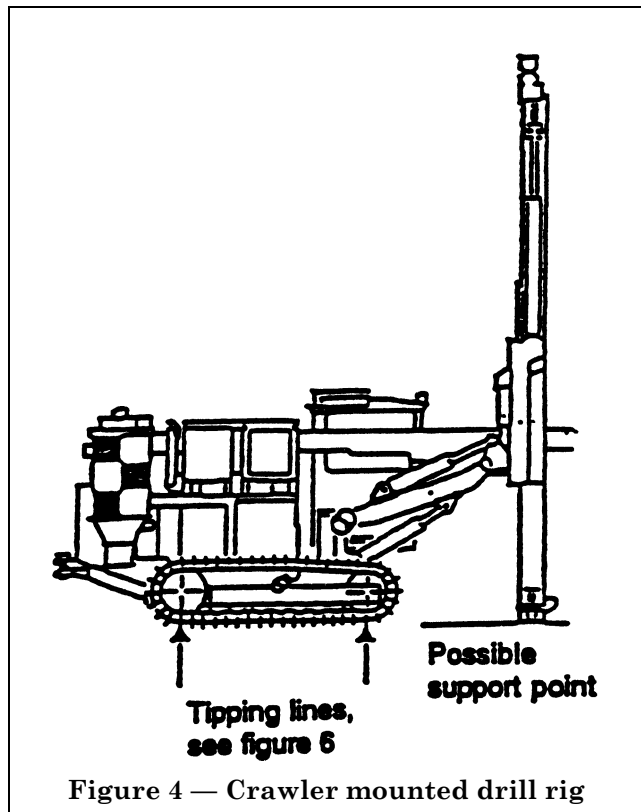
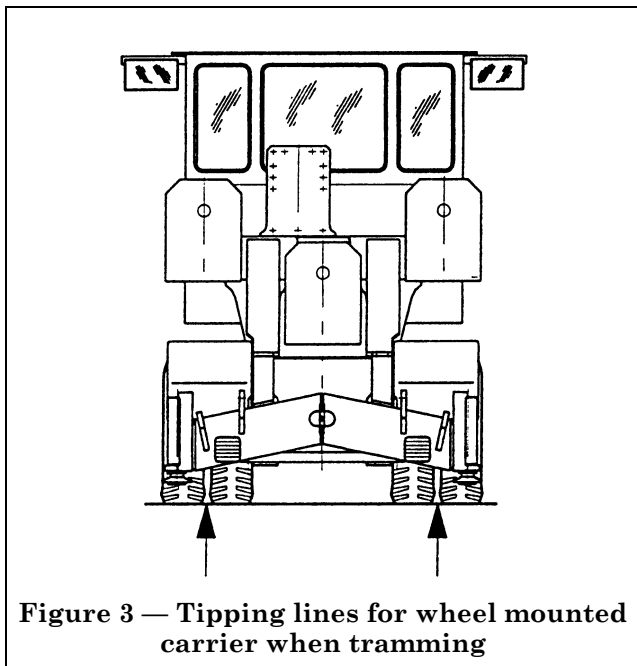

Figure 2 — Wheel mounted drill rig



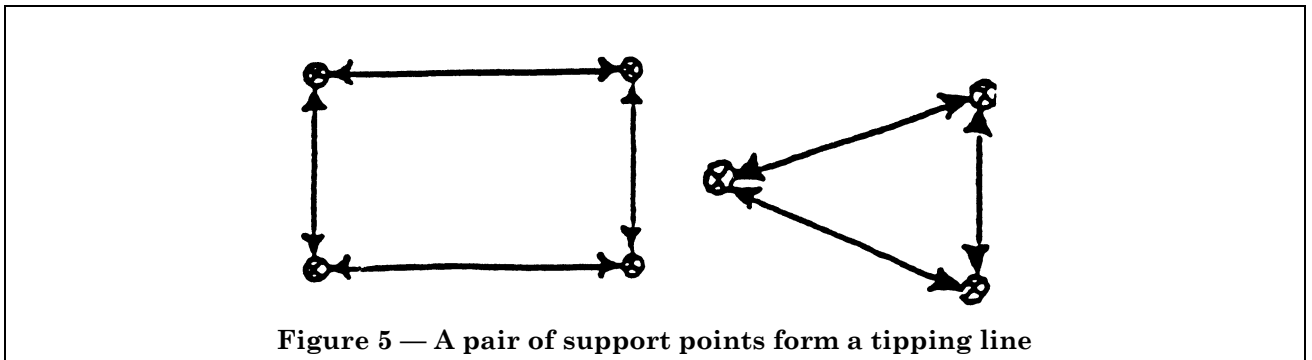

Figure 5 — A pair of support points form a tipping line

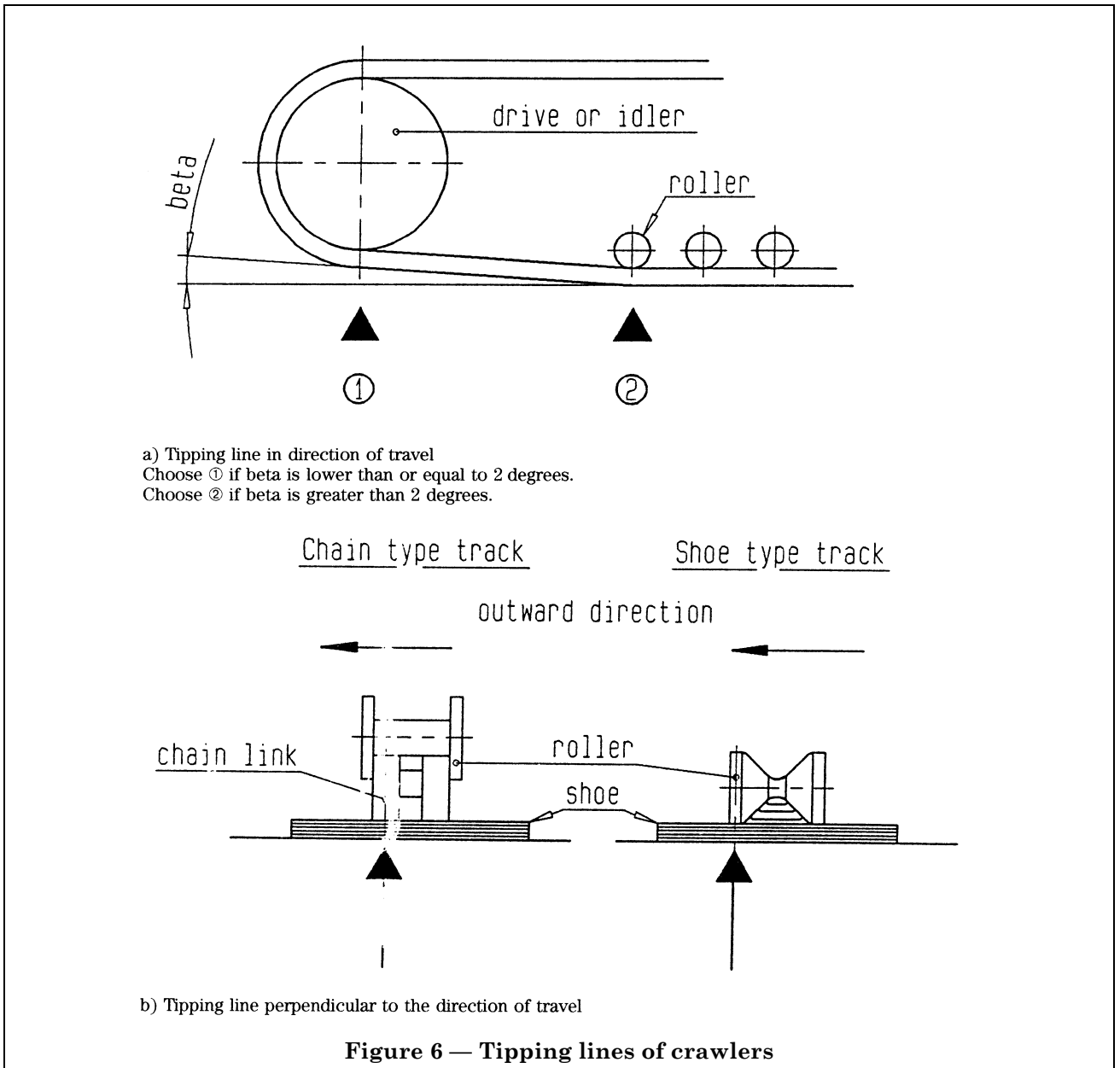
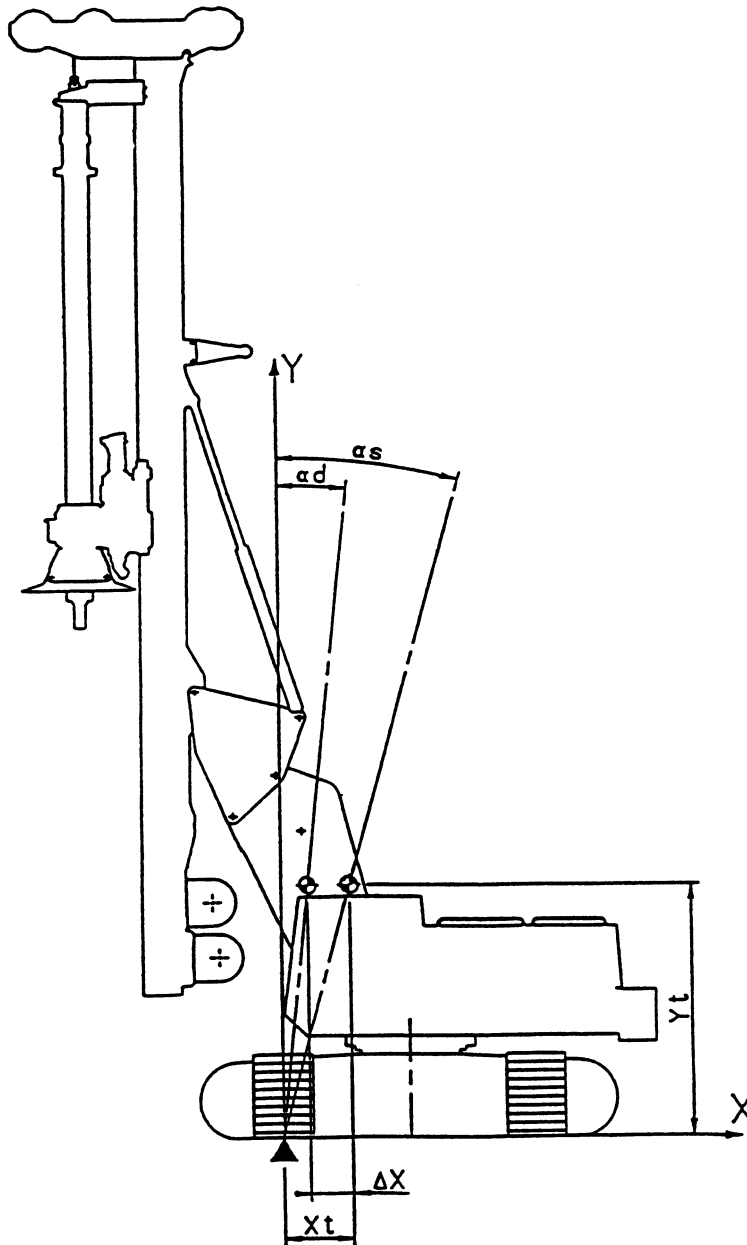

Figure 6 — Tipping lines of crawlers



$$\tan \alpha_d = \frac{X_t - \Delta x}{Y_t}$$

Figure 7 — Stability angle

5.5.3.6 Operating conditions

The stability of the drill rig shall be calculated for the following operating conditions which shall be stated in the operator's instructions.

- a) Working

The calculation shall be carried out for the most unfavourable combination of conditions that may occur (see examples below):

- booms, service platforms and feed extension in advanced positions and turned to the limit of the working area. The rated load shall be applied to the service platform;

- steering turned in the extreme and most unfavourable position (articulated carrier);
- mast at the utmost front upward position and maximum forward mast inclination;
- attachments at their highest position;
- most unfavourable choice of tipping line;
- wind coming from the most unfavourable direction;
- centrifugal force applied to the superstructure;
- maximum pulling force on the rope suspended tool in the bore hole.

The effect of overturning moments is equivalent to, and can be taken into account as, an apparent horizontal forward displacement  $\Delta x$  of the total centre of gravity of the drill rig.

The total apparent displacement of the centre of gravity is expressed as follows:

$$\Delta_x = (M_w + M_a + M_f)/G_t$$

where the moments due to wind, centrifugal and other forces are calculated in the most unfavourable simultaneous combination that may occur as foreseen in the operator's instructions.

The stability angle is calculated:

$$\tan \alpha_d = (X_t - \Delta_x)/Y_t$$

#### b) Trimming

Stability in trimming shall be calculated for the specified conditions as stated in the operator's instructions, taking into account the most unfavourable case.

#### c) Working on slopes

The stability calculations shall be done for the most unfavourable combination of gradient and load condition as allowed in the operator's instruction.

#### 5.5.3.7 System for the measurement of inclination as regards stability

For checking the stability under trimming condition and whilst working with a capacity table, the drill rig shall be equipped with a measuring system e.g. an inclinometer. The measuring system shall show the operator the actual absolute forward, backward and lateral inclination of the drill mast (when this is relevant to the stability). If major parts of the drill rig can be moved horizontally and this has an effect on the stability, the operator shall be able to determine the position of these parts from the operator's position.

A simple system for measuring the absolute inclination of the drill rig shall be provided, e.g. a bubble level or a pendulum system.

#### 5.5.3.8 Stability of truck and trailer mounted drill rigs

In addition to the above mentioned criteria the following shall be considered. When a drill rig and its auxiliary equipment is mounted on a track or trailer chassis, the weight distribution, the axle and tyre loading shall be within the limits specified by the vehicle manufacturer.

Consideration shall be given to the effect of the vehicle suspension.

#### 5.5.4 Ground pressure, calculation for crawler mounted drill rigs

##### 5.5.4.1 General

For crawler mounted drill rigs the highest ground pressure which can occur shall be calculated according to 5.5.4.2 for the operating conditions according to 5.5.3.6. The values shall be stated in the operator's instructions.

##### 5.5.4.2 Calculation of ground pressures

The calculation of the maximum ground pressure that can occur in the contact point between tracks and ground shall be carried out in accordance with Figure 8. The total vertical resultant force, see 3.11, in its point of application, shall be divided into single loads,  $P$ , on each track according to the position of the resultant force.

Definition of parameters:

$P$	is the load on one track, in N;
$e$	is the eccentricity of the load $P$ , in m, see Figure 8;
$d$	is the distance between the idler and driver, in m;
$b$	is the width of the track grouser, in m;
$\sigma_2, \sigma_1$	are the maximum and minimum ground pressures, in Pa.

#### 5.6 Carrier brakes

##### 5.6.1 General

It shall be possible to slow down, stop and hold at rest self-propelled rigs so as to ensure safety under all conditions of service, speed, ground conditions and gradients as specified by the manufacturer.

Braking systems may use common components, however in the case of a failure of any single component other than a tyre, the braking system shall be capable of bringing the drill rig to a halt in accordance with the performance requirements specified for the secondary braking system.

It shall not be possible from the operator's position to disconnect the brakes from the wheels or tracks.

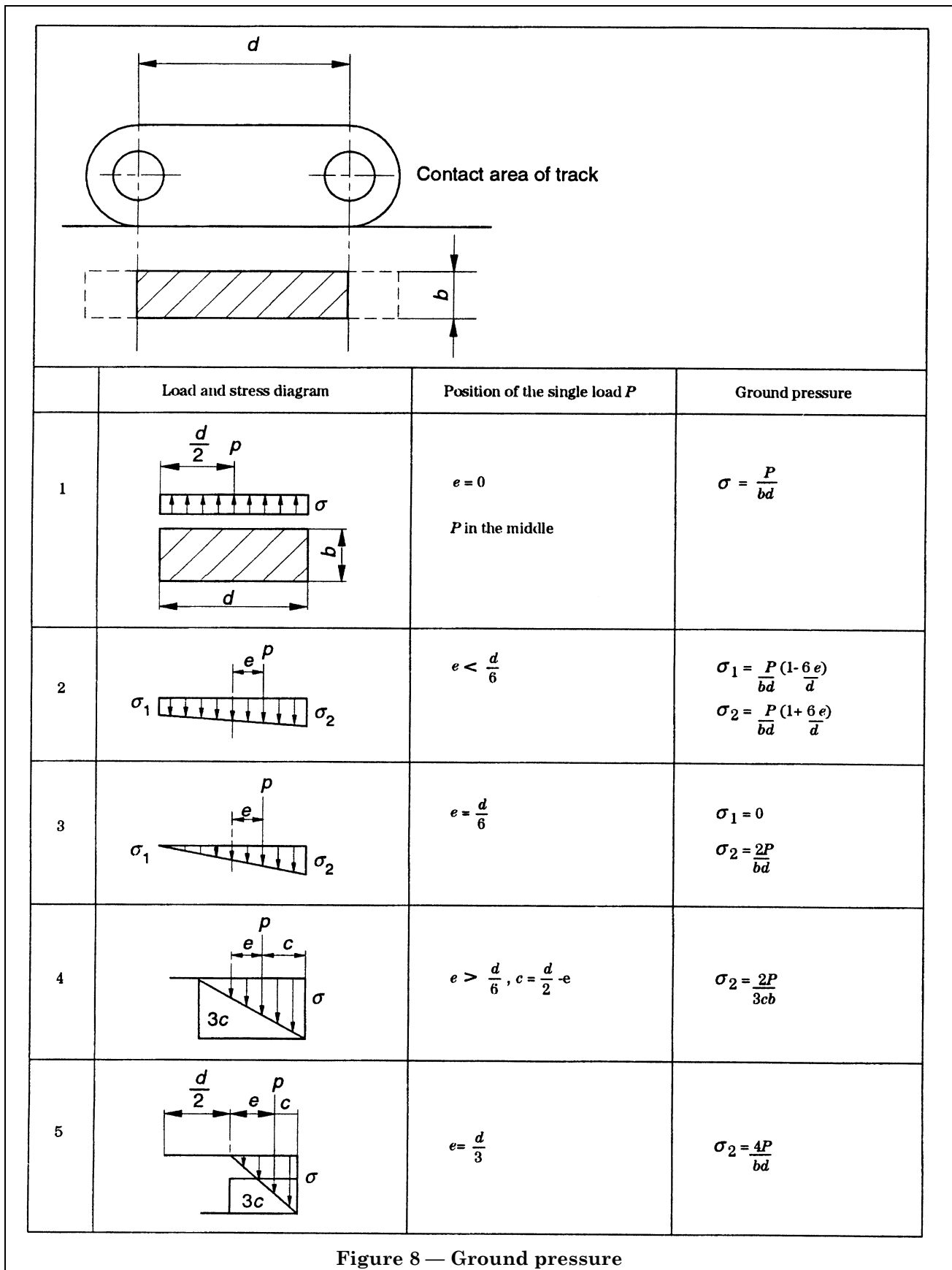

Figure 8 — Ground pressure

Where the operation of the service braking system depends on accumulated hydraulic or pneumatic energy and in case the power source becomes inoperative, the system shall be capable of sustaining at least five consecutive applications of the brakes. On the fifth application the brake performance shall not be less than that specified for the secondary braking system.

Where braking systems use an energy reservoir, a pressure gauge shall be located in the driver's field of vision. The minimum pressure required shall be marked on the pressure gauge by a red mark. Alternatively, a warning device complying with 6.6 of ISO 3450:1985 may be provided.

A drill rig, which has any type of remote control for moving, shall be so designed, that in case the driver should lose control for any reason, the machine shall stop automatically.

For truck, tractor and trailer mounted drill rigs the relevant road traffic regulations regarding the vehicle brakes apply.

#### **5.6.2 General requirements for wheel mounted drill rigs**

Wheel mounted drill rigs shall be equipped with:

- a service braking system;
- a secondary braking system;
- a parking braking system.

The braking system controls shall fulfil the requirements of 8.1 of ISO 3450:1985.

Pneumatic and hydraulic braking systems shall be designed as dual circuit systems such that at least two wheels on opposite sides of the vehicle are braked in the event of a leak.

Provisions for examining brake wear and brake fluid level in any reservoir shall be made.

#### **5.6.3 Service braking system for wheel mounted drill rigs**

The service braking system shall give a braking force, in N, equivalent to not less than 35 % of the maximum drill rig mass multiplied by 9,81. For manoeuvring and holding drill rigs on steep slopes see also 5.15.3.

In addition to this requirement, the service brake system shall be capable of retarding the drill rig with at least  $1 \text{ m/s}^2$  on the maximum permitted gradient as specified by the manufacturer.

For drill rigs with hydrostatic transmission, service braking action may be performed by means of the hydrostatic transmission if the performance requirements given above are fulfilled.

The service brake shall be resistant to fade due to heat, see C.2.3.

#### **5.6.4 Secondary braking system for wheel mounted drill rigs**

A secondary braking system shall be provided to stop the drill rig in any condition of service, speed, ground and gradient as specified by the manufacturer, in the event of any failure in the service braking system.

The secondary braking system shall give a braking force in N, equivalent to not less than 25 % of the maximum drill rig mass multiplied by 9,81.

In addition to this requirement, the secondary brake system shall be capable of retarding the drill rig with at least  $1 \text{ m/s}^2$  on the maximum permitted gradient as specified by the manufacturer. To achieve this brake force, the parking brake may be used in addition.

For drill rigs with an hydrostatic service brake, the secondary braking system shall also achieve independently the braking performance specified for the service brake.

#### **5.6.5 Parking braking system for wheel and crawler mounted drill rigs**

A purely mechanical parking braking system for holding machines in a stationary position shall be provided. The parking braking system shall be latching.

The parking braking system shall be able to hold the drill rig on the steepest slope it is allowed to operate on, up to a maximum of  $20^\circ$ , according to the manufacturer's specification with a safety factor of 1,2. For operating on slopes steeper than  $20^\circ$ , see 5.15.3.

#### **5.6.6 The service, secondary and parking braking systems on crawler mounted drill rigs**

Crawler drill rigs shall have either a service and secondary braking system according to the requirements of 5.6.3 and 5.6.4 or two service brakes, one on each track. These shall be controlled individually e.g. by two separate control systems, one on each track. The braking system may be combined with the steering system.

The combined service brakes system shall give a minimum brake force in N, equivalent to the force on the drill rig on a slope as specified by the manufacturer up to a highest gradient of  $20^\circ$ , multiplied with a factor of 1,2. For operation of drill rigs on steeper slopes see 5.15.3.

This requirement shall be verified as a static gradient test or a pull test as specified in C.2.5.

One of the two fully independent braking systems is accepted as the secondary braking system in case of failure of the other brake.

The parking brake may be the same brake as the service brake if it is mechanically spring loaded for automatic braking action in case of loss of power supply. Otherwise the parking brake shall be in accordance with the requirements in **5.6.5**.

#### **5.6.7 Braking systems for “skid steer” wheel mounted drill rigs**

For skid steer chassis the same rules as for crawler mounted drill rigs shall apply. Braking action shall be possible on all wheels.

#### **5.6.8 Verification**

The brakes of a wheel mounted drill rig shall be tested in accordance with the requirements in Annex C.

The brakes of crawler mounted drill rigs shall be tested in accordance with **C.2.5**. The parking brakes of towed drill rigs shall be tested according to **C.2.5**.

**NOTE** These verifications are not necessary for truck and tractor mounted drill rigs which are certified to meet the requirements of road traffic regulations.

### **5.7 Protection against moving parts**

#### **5.7.1 General**

The moving parts of a drill rig shall be designed, built and laid out to avoid hazards as described in EN 292-1:1991. For exceptions to this general rule see **5.7.3**.

#### **5.7.2 Transmission parts**

Rotating transmission parts such as drive shafts, couplings, belt drives, which are within reach of personnel, shall be provided with guards to prevent contact. Guards shall comply with prEN 953. Guards shall be of robust construction and securely held in place. Fixed guards shall be used when access is rarely necessary and be held in position either by welding or by mounting them in such a way that they can be opened or removed only with the aid of tools or keys.

**NOTE 1** EN 292-2:1991 sets out the general principles for the guarding of moving parts.

When frequent access is required for service or maintenance purposes, movable guards may be fitted. They shall fulfil the following requirements:

- whenever possible they shall remain fixed to the machine when open;
- they shall be fitted with a system supporting them in the open position;

**NOTE 2** The support may be locking, latching or springloaded.

— compartments containing internal combustion engines shall be lockable. Movable covers, preventing access to such compartments need not have locking devices if the guards have to be either opened by the use of a tool or a key, or by a control located at the driver’s position of the drill rig, if this position is in a fully enclosed cab with a lock to prevent unauthorized access.

#### **5.7.3 Moving parts involved in the working process**

##### **5.7.3.1 General**

The drill rig shall be so designed, constructed and equipped that manual operation in the danger zone is minimized.

Where an operator has a working position in the danger zone and is exposed to hazards from moving parts involving rotating tools, rods or drill pipes and sliding rotary head the following hazardous situations are of particular concern:

- adding and retrieving of a drill rod, drill pipe or casing;
- breaking of thread connections of the drill string;
- handling of drilling components;
- supervision of drilling operation;
- changing of drilling tools.

For protection devices and systems see **5.3.3.2** and **5.4.2.2**.

##### **5.7.3.2 Drill rigs using threaded drill string connections**

A powered drill rod break out system shall be installed on drill rigs using threaded drill rods if feasible. The break out system shall obviate the need to use hand tools in the break out operation.

**NOTE** The following designs are regarded as being valid parts of a powered drill rod break out system:

- a) on drill rigs with top hammers, the percussive mechanism is regarded as being a part of the powered drill rod break out system;
- b) on rotary top drive drill rigs, the controlled reverse rotation of the head drive, together with the use of a chuck device or equivalent lockable rotating connection is regarded as being a powered drill rod break out system;
- c) on rotary spindle drill rigs, the controlled reverse rotation of the chuck or an equivalent lockable rotating connection and the rotation of the spindle is regarded as being a part of a powered drill rod break out system.

### 5.7.3.3 Drill rod handling systems

If the mass of a rod or drill pipe causes an operator to handle more than 25 kg, the drill rig shall be provided with a mechanized rod or pipe handling system.

If the application of a drill rig does not allow the use of a mechanized rod or pipe handling system, the drill rig shall be fitted with a lifting device allowing safe transfer of the rods and/or pipes from the pipe rock to the drill axis and vice versa.

NOTE A swingable rotary head with a chuck or a travelling block either with an elevator, lifting cap, pulling out flange, lifting sling or similar is considered as being sufficient.

### 5.7.3.4 Restricted area in face drilling

The area in front of the drill rig i.e. between the carrier and the tunnel face, within the danger zone, shall be a restricted access area when drilling and warning signs shall be provided on the rig.

The shape and design of signs shall be in accordance with 7.2.2. From the operator's position it shall be possible to see clearly that no personnel are in the danger zone. See also 5.2.4.

When there is a need for a helper to work in the danger zone during the drilling operation, this shall only be done in accordance with 7.4.3 and 7.4.5.

### 5.7.3.5 Drill rigs with a turnable superstructure

The danger zone of the drill rig shall be a restricted access area when drilling and turning the superstructure of the drill rig.

The drill rig shall be provided with warning signs in accordance with 7.2.2. See also 5.2.4.

When there is a need for a helper to work in the danger zone during the drilling process this shall only be done in accordance with 7.4.3 and 7.4.5.

## 5.8 Electrical installations

### 5.8.1 Electric power installation

The electric power installation of drill rigs shall comply with the requirements of EN 60204-1:1992, in particular clauses 4, 5, 6, 14, 15, and 16.

An earth fault protection system shall be provided for electrically powered drill rigs.

NOTE A revised edition of EN 60204-1:1992 dealing with electric installations on mining equipment is under preparation. Until the revised standard is published, national regulations and standards apply.

### 5.8.2 Battery installation

The batteries shall be provided with lifting points and be firmly attached to their location. There shall be no risk of electrolyte splashing persons and surrounding equipment. The terminals shall be guarded and an isolator switch shall be fitted in the circuit, see 4.11 of ISO 3457:1986.

Batteries and/or battery locations shall be designed and built or covered so that there is no risk to the operator caused by battery electrolyte or vapours even in the event of overturning of the drill rig, see 4.10 of ISO 3457:1986.

## 5.9 Hydraulic installations

The hydraulic systems shall comply with the safety requirements of 3.8 of EN 292-2:1991 and prEN 982.

Non-toxic hydraulic fluids shall be used.

Hydraulic cylinders used for erection and lifting shall be fitted with load-sustaining devices mounted on the cylinder and shall be self bleeding or fitted with an air bleed point at the highest point.

NOTE Bleeding can also be made by moving the piston between full stroke movements.

Flexible hydraulic hoses intended for pressures higher than 15 MPa shall be fitted with swaged fittings.

Hydraulic hoses and pipes shall be separated from electric power wiring and be guarded against hot surfaces and sharp edges.

Pipes and hoses which have to be disconnected in operation shall be fitted with self sealing couplings with built-in check valves. Couplings shall be marked to ensure correct reconnection.

The tanks for hydraulic fluid shall be fitted with level indicators. The filling point of the tank shall be so designed that overflow is prevented when working on any gradient for which the drill rig is designed.

A temperature gauge or a monitor, which gives a warning signal if the allowed temperature is exceeded, shall be provided.

## 5.10 Pneumatic installations

Pneumatic installations shall comply with the safety requirements of prEN 983.

## 5.11 Lighting

### 5.11.1 Working light

For underground work e.g. mining and tunnelling, the drill rig shall be fitted with working light illuminating the tunnel face i.e. the area within the reach of the drilling booms, giving a minimum illumination of 100 lx apart from natural shadows from feeds and booms.

For other drilling operations lighting shall be fitted giving an illumination of at least 100 lx of the area around the point of drilling.

For surface drill rigs, specified to work in darkness and non-lit conditions, lighting shall be fitted giving an illumination of at least 100 lx of the area around the point of drilling and winching apart from natural shadows from the feeds and booms.

White light shall be used.

### 5.11.2 *Illumination when tramming*

For self-propelled drill rigs tramming in darkness, lighting shall be provided giving an illumination of at least 10 lx at a distance of 7 m from the drill rig and in the direction of movement.

## 5.12 Fire protection

### 5.12.1 *General*

Materials used in the construction of drill rigs shall be fire resistant as far as possible. Cab interior upholstery shall be made of flame retardant material which has a linear velocity of flame propagation of maximum 250 mm/min when tested in accordance with ISO 3795:1989.

### 5.12.2 *Fire extinguishers*

On any drill rig with a power rating not exceeding 50 kW, at least one fire extinguisher, having an agent with a mass of not less than 2 kg, shall be provided.

For a drill rig with a power rating above 50 kW but below 200 kW, at least one fire extinguisher, having an agent with a mass of not less than 6 kg, shall be provided.

For drill rigs with a power rating exceeding 200 kW, at least two fire extinguishers, each having an agent with a mass of not less than 6 kg shall be provided.

Fire extinguishers shall be suitable for both extinguishing oil fires and fires in electrical installations.

For the fire protection of diesel driven underground drill rigs, there shall be an on-board, built in fire extinguishing system covering the diesel engine compartment and equipped with:

- a manual triggering device for manned drill rigs;
- an automatic triggering system on remotely controlled, unmanned or partly manned drill rigs.

If a fixed fire suppression system is built in, at least one portable fire extinguisher shall be fitted to the drill rig.

The fire extinguishers shall fulfil the requirements of EN 3:1975.

### 5.12.3 *Installation of fire extinguishers*

The fire extinguishers shall be located in the immediate vicinity of the operator or, in case of remotely controlled drill rigs, in another clearly visible and easily accessible place.

The fire extinguishers shall be mounted so that tools are not needed for removing the fire extinguishers from the brackets.

If there is more than one fire extinguisher on the drill rig, they shall be mounted on different sides of the rig.

Fire extinguishers shall not be placed near areas with a high fire risk e.g. power units, fuel tanks. The fire extinguishers shall be positioned between the operator and such an area.

## 5.13 Noise and vibration

### 5.13.1 *General*

The noise and vibration levels during drilling are heavily influenced by the drilling process. Hence the test conditions of Annex A are designed to give a value which is repeatable and only conditionally comparable with values obtained in a real operation. The operator's significant exposure to noise and vibration occurs during drilling.

NOTE Tramming is of short duration and therefore has little or no influence on the total noise emission and vibration exposure.

### 5.13.2 *Noise*

Drill rigs shall be so designed and constructed that risks resulting from the emission of airborne noise are reduced to a low level taking account of technical progress and the availability of means of reducing noise, in particular at source.

The measurement of the noise emission from the drill rig and the noise level at the operators' positions shall be measured in accordance with Annex A and shall be stated in the operator's instructions, see 7.4.2.

NOTE This standard does not give any information on how to reduce noise.

### 5.13.3 *Vibration*

Drill rigs shall be so designed and constructed that the risk to the operator resulting from vibration is reduced to a low level taking account of technical progress. Vibrations during drilling affecting the whole body of the operator, sitting or standing at the working position, shall be measured in accordance with Annex A and shall be stated in the operator's instructions, see 7.4.2.

NOTE This standard does not give any information on how to reduce vibration.

## 5.14 Dust and gases

### 5.14.1 *Dust suppression*

All drill rigs using compressed air as a flushing medium shall be equipped with a dust suppression system. Water or foam injection into the flushing air are acceptable methods. If flushing is carried out with dry compressed air a dust extraction system shall be installed on the rig.

The exact performance of the dust extraction system will depend on site conditions and therefore no exact performance criteria can be stated.

For underground drilling, water shall be used as flushing medium wherever feasible. The control system for the drilling shall wherever feasible be so designed and constructed that the dust suppression or extraction system is automatically in operation when drilling is started.

### 5.14.2 Engines and engine exhausts

#### 5.14.2.1 General

Exhaust gases from internal combustion engines of drill rigs shall be directed away from the operating position.

When working in situations where flammable gases could be present in the atmosphere or emanating from the drilling operation, all exhaust systems shall be fitted with spark arresters.

#### 5.14.2.2 Underground use

Exhaust gases from internal combustion engines of drill rigs intended for use in underground workings shall not be discharged upwards.

Only diesel engines operated with fuel with a flash point of more than 55 °C (diesel fuel) shall be used.

## 5.15 Draw-works, winches and ropes

### 5.15.1 General

Winches, ropes and sheaves for lifting which are integral parts of the drill rig and directly involved in the drilling process shall fulfil the requirements stated in 5.15.2.

NOTE Such systems are:

- systems running drill rods, chisels, kelly bars, hammer grabs and other impact tools, by free fall, controlled free fall or powered lowering;
- systems running drill rods, casings, tools and other accessories in and out of the bore hole;
- cable feed systems;
- any other system using winches, ropes and sheaves for any purpose other than lifting goods and personnel.

For requirements on winches, ropes and sheaves for personnel lifts and movable platforms, see 5.17.3 and 5.17.4.

### 5.15.2 Safety requirements

The following minimum safety requirements shall be met:

Rope safety factors:

- for running ropes in the normal operating case 3,0
- for running ropes in the exceptional operating case 2,0<sup>a</sup>
- for erection ropes, guy ropes, pendant ropes 2,5
- for cable tool drilling; percussion drilling 5,0<sup>b</sup>
- for feed ropes 3,0

<sup>a</sup> Exceptional operations can only be initiated by an intentional, controlled action.

<sup>b</sup> The safety factor 5,0 is the ratio between minimal breaking load and the static weight of the drilling tool.

Diameters:

- winch drum pitch 16,0*d*
- pulley pitch 18,0*d*
- compensation pulley pitch 14,0*d*
- pulley in the feed system 12,5*d*

where

*d* is the diameter of the rope.

All pulley assemblies shall be provided with devices preventing the rope from disengaging.

Rope end connections using U-bolted clamps are not permitted.

There shall always remain at least three wraps of rope on the winch drum. The rope fastening on the drum shall be such that the fastening strength is at least 70 % of the maximum allowed rope load.

The maximum line pull on the first rope layer of the draw-works/winches shall be indicated on the data plate of the winch.

Draw works and winches shall be equipped with:

- a service brake system;
- a holding brake system.

The holding brake systems shall act automatically and prevent an unintentional running back of the load if the winch control levers are not actuated or in the case of failure of the energy supply.

NOTE The brake systems may use common components. The load lowering valves of hydraulically powered winches or lowering devices are considered to be service brake systems.

Both brake systems shall each hold a minimum of 1,3 times the maximum allowed line pull. The service brake shall enable the operator to retard and stop a descending load smoothly.

If the service brake is coupled to the winch or draw-work by means of a disengagable clutch, a device shall be installed, which is visible to the operator and indicates whether the clutch is engaged or not.

If an electrical eddy-current brake or a fluid fly-wheel brake is fitted as the service brake, all information necessary for the operation, for example rotational speed, temperature, water flow rate, operating voltage, shall be indicated within the view of the winch operator.

Winches or draw-works having an influence on stability shall have a measuring system indicating the actual line pull of the rope or the hook load. A capacity table visible to the operator shall show the allowed line pull.

Draw-works or drill mast winches shall have a limiting device stopping the lifting movement by influencing the winch control, before the mechanical end position is reached. For winches with a capacity equal to or less than 20 kN a mechanical limit stopping device without influence on the winch control is sufficient.

Activation of the free fall function of the winch shall only be possible by actuation of two independent controls simultaneously. Both controls shall be of the hold-to-run type.

When a winch is designed for several functions, including a free fall function, a key operated control shall be additionally fitted, which allows the free fall function to be operated.

### 5.15.3 Winches for operating a drill rig on slopes

A winch shall be installed on a drill rig which is intended to operate and travel on slopes, having a gradient angle higher than 20°, to prevent the drill rig from sliding down the slope. For those winches the following requirements apply.

The relative rated pulling force,  $f$ , on the third layer of the rope on the winch drum, shall be chosen in accordance with the operating gradients stated below:

- $f > 0,50$  for a gradient angle of  $< 40^\circ$
- $f > 0,40$  for a gradient angle of  $< 35^\circ$
- $f > 0,30$  for a gradient angle of  $< 30^\circ$
- $f > 0,20$  for a gradient angle of  $< 25^\circ$

where

$$f = \frac{\text{Pulling force in } N}{\text{Mass of drill rig} \times g}$$

Winches for free fall operation shall not be used.

The braking capacity of the winch shall not be less than 1,2 times the pulling force but not exceed 1,6 times the pulling force.

The wire rope safety factor shall not be less than 3.

The application of a winch shall not be included as a support in the stability calculation.

### 5.16 Roller and leaf chains

Roller and leaf chains, which may be an integral part of the feed system of a drill rig and are directly involved in the pull-down and pull-up operation, shall fulfil the following requirements:

- they shall be selected with a safety factor, i.e. minimum breaking force in relation to maximum load, of 3,5;
- an adequate and safe means of tensioning shall be provided;
- where possible, chains shall wrap 180° around sprockets or guide pulleys.

## 5.17 Masts, derricks, feed beams and working platforms

### 5.17.1 General

Mechanically raised masts, derricks and feed beams shall be equipped with a safety device designed to engage automatically in the event of failure of the lifting mechanism to prevent the mast from falling. For hydraulically raised masts and feed beams, see 5.9.

Locking pins or other removable devices for holding erected masts and feed beams in place shall be secured against unintentional loosening. Pins or securing devices shall be captive and attached at the locking point using a chain or similar.

Due consideration shall be given to stresses caused by the asymmetrical rocking of drill rods or rod magazines. When guy ropes are necessary for masts and derricks the pre-tensioning shall be laid down in a tension diagram. It shall be possible to control tension forces.

The rated load (normal load or pull-up force) of masts, derricks and feed beams shall be clearly displayed at the operator's position.

### 5.17.2 Racking and working platforms

All platforms shall be designed to be safely accessed by means of suitably positioned ladders or stairways.

If ladders are longer than 3 m, suitably placed and spaced backloops shall be provided, or provisions shall be made to allow safety harnesses to be coupled to the ladders. If ladders are more than 9 m long, landings shall be provided at intervals of maximum 9 m. This does not apply to elevator working platforms.

Working platforms shall be designed without intermediate steps. They shall be so constructed that they possess sufficient area to accommodate the equipment being used.

Racking and working platforms shall be provided with weather protective cladding.

Racking and crown platforms shall be provided with anchor points for safety harness attachment.

Racking platforms shall completely cover the space between the working edges and the main structural members to which they are secured and they shall be level with the drill rod support racking. The outer edges shall be equipped with guard rails and toe boards in accordance with clauses 8 and 9 of ISO 2867:1989.

The inside edges of the platform shall be placed to allow safe clearance for passing through drilling equipment.

Finger boards, crown platforms and auxiliary platforms shall be designed to carry a single load of at least 1,5 kN in the most unfavourable position.

### 5.17.3 Personnel lift for operational work

For definition of personnel lift see 3.17. Any personnel lift provided for operational work shall be outside the danger zone of the rotating drill string and shall be provided with limiting controls for the highest and lowest positions.

The personnel lift for operational work shall be equipped with one of the following devices:

- a gripping device which acts on the guide rails and which will operate when the nominal lowering speed is exceeded by more than 40 %; or
- a speed limiting device, which limits the lowering speed to maximum 1,4 times the nominal lowering speed if a defect should occur in the hoisting mechanism; or
- a gripping device which acts on the guide rails and which in case of cable breakage shall enter into operation in combination with a winch brake acting automatically and directly on the winch drum independent of the drive. The drive shall be self-braking. The drop height, before the entering into operation of the grip, may not exceed 0,3 m; or
- an individual fall arrester, for each person in the lift; or
- a fall retarder, connected to a safe, defined part, which will operate at a specific drop speed.

An anti slack line protection device shall always be provided.

The hoisting steel wire rope shall have a diameter of at least 8 mm and a safety factor of at least 10.

The diameter of the sheaves and the winch drum shall be at least 26 times the diameter of the steel wire rope.

The hoist and lowering speed of the personnel lift shall not exceed 0,5 m/s.

### 5.17.4 Movable platforms for service, maintenance and repair

For definition of movable platform, see 3.18.

NOTE Personnel lifts for operational work may also be used for service, maintenance and repair.

In the design calculation, the overall weight of the movable platform shall include the weight of the platform and material carried plus 1 kN for each person carried, a minimum overall weight of 5 kN shall however be applied. A safety factor of 1,25 shall be applied to the overall weight.

Where rope or chain is used for suspension of the drilling equipment to which the movable platform is attached, the safety factor of the suspension rope or chain shall be at least 10.

In case of cylinder suspension the load carrying side of the cylinders shall be fitted with a directly mounted load-sustaining device.

Winches used for movable platforms shall conform to the requirements of 5.15.2 but with a rope safety factor increased to 10. No free fall winches shall be used and an anti slack line device shall be provided.

The lifting and lowering speed of the movable platform shall not exceed 0,5 m/s.

### 5.17.5 Access

Guard rails and access to personnel lifts and movable platforms on drill derricks shall comply with ISO 2867:1989. The access shall be fitted with an automatically closing device. If the access is a gate, this gate shall not open outwards.

### 5.17.6 Escape systems

Escape devices shall be provided from upper fixed working platforms where the height exceeds 10 m. They shall be arranged and placed so as to permit personnel to descend at a controllable and safe speed to a safe place. The safety system shall be installed and ready for immediate use.

## 5.18 Special requirements for remotely controlled and automated drill rigs

### 5.18.1 Operating position

A drill rig, without an operator's position on it, shall be provided with at least an attachment for a control box, from which the drill rig can be controlled.

Starting and stopping of the drill rig shall only be possible from controls on the drill rig or from a control position with a sufficient visibility over the operating area e.g. by means of a TV-monitoring system. The drill rig shall be fitted with a visual and/or audible warning that shall, before starting, automatically be actuated, indicating that the drill rig is operating in a remotely controlled or automatic mode.

### 5.18.2 Emergency stop

The drill rig shall be fitted with an emergency stop, located on the control panel in the control/monitoring position and additional emergency stops shall be fitted on the drill rig, which are safely and easily accessible from outside of the drill rig.

### **5.18.3 Control system**

The drill rig's control circuits shall be so designed that the operations stop automatically in case of an interruption or break down of the control link between the operator and the drill rig, or when the initiated sequence has been completed.

An unmanned, automatically operated drill rig's control system shall be designed with an integrated diagnostic system that shuts down the operation when a fault or an abnormal operational behaviour is detected by the system.

Resetting, after a fault in part of the system, shall not restart any automatic function.

Restarting of the operation shall only be possible by an intentional action by the operator.

The drill rig shall be provided with a selector switch for selecting local or remote control mode. The local control shall always have priority over the remote control.

Electrical and electronic control systems shall conform to EN 50081-2:1993 and EN 50082-2:1994 with regard to electromagnetic compatibility.

### **5.18.4 Fire protection**

Remotely controlled and automated underground drill rigs shall be equipped with an automatically triggered, built-in fire extinguishing system covering the diesel engine installation and the electrical power system, e.g. motors, electrical cabinets and on-board power cables. It shall also be possible to trigger the fire extinguishing system from the control panel and/or (if applicable) from the monitoring position.

In addition the requirements of **5.12** also apply.

### **5.19 Warning devices**

Warning devices such as signals, etc. shall be unambiguous and easily perceived. The operator shall have the facility to check the operation of all essential warning devices at all times.

There shall be a manually operated, audible alert signal to warn personnel in the working area of impending danger. It shall be possible to operate the audible warning from each driving or operating position including (if applicable) a remotely situated monitoring position. The sound pressure of the warning signal shall be at least 5 dB higher than the noise generated by the drill rig at a distance of 2 m when operated in accordance with Annex A. There shall also be an automatic, audible or visual warning signal given when reversing.

A remotely controlled and/or unmanned, automatically operating drill rig shall be provided with a visual warning light which shall be automatically actuated before starting and when the drill rig is working in remote control or automatic mode.

This requirement is not valid for a remotely controlled drill rig with the control panel situated in the vicinity of the drill rig and where there is a direct visual contact between the operator and the drill rig.

## **6 Verification of safety requirements/measures**

Verification of compliance with the safety requirements given in this standard shall be made by calculation, inspection and, whenever feasible, testing, if the verification requirements are not explicitly stated in the pertinent clauses, i.e. stability, brakes, noise and vibration.

All lifting and feed systems shall be tested at their rated capacities.

The verifications shall be carried out before delivery to the user.

## **7 Instructions for use — Instruction handbooks**

### **7.1 Marking — Data plate**

The data plates for the drill rig and its winches shall give at least the following information:

- a) name and address of the manufacturer;
- b) name of machine;
- c) type designation;
- d) serial number;
- e) installed power, in kW;
- f) rated voltage and frequency of the electrical installation;
- g) total mass of machine in kg, as supplied;
- h) normal hook load for each allowed reeving pattern of the draw-works and/or winches;
- i) exceptional hook load for each allowed reeving pattern of the draw-works and/or winches, if applicable;
- j) pull-down and pull-up force, if applicable;
- k) mandatory marks<sup>1)</sup>;
- l) the classification number for flame and explosion protection, if applicable.

---

<sup>1)</sup> For EU countries, CE mark.

## 7.2 Indicators

### 7.2.1 Information indicators

The information needed to control a drill rig shall be presented in an unambiguous manner and so that it is easily understood. Pictograms are preferred, see Annex E.

### 7.2.2 Warning signs for residual hazards

Where hazards remain despite all measures adopted or in the case of potential hazards which are not evident, warnings shall be provided.

Such warnings shall preferably use readily understandable pictograms, see Annex E, and/or be drawn up in the languages as required in 7.4.1.

The drill rig shall be equipped with warning signs forbidding entry of unauthorized personnel into the working area of the machine.

A remotely controlled and/or unmanned, automatically operated drill rig shall be equipped with signs warning that the drill rig is remotely and/or automatically operated.

## 7.3 Maintenance

It shall be possible to carry out adjustment, maintenance, lubrication, repair, cleaning and service operations while the drill rig is shut down and the prime mover stopped.

If for technical reasons one or more of the above work items cannot be carried out under a shut down condition, precautions shall be taken so that the work can be carried out safely, see 7.4.5.

In case of automated drill rigs and where necessary also on other machines, provisions shall be made for diagnostic fault finding equipment. Measuring points and/or locations of diagnostic fault finding equipment shall be clearly marked in figures and/or tables in the maintenance instructions.

Winches and ropes shall be subject to frequent inspection or examination because of the unforeseeable wear pattern. Examination and discard criteria shall be in accordance with Annex B.

## 7.4 Instruction handbooks for drill rigs

### 7.4.1 General

The instruction handbooks shall be drawn up according to 5.5 of EN 292-2:1991.

The following instruction handbooks shall be supplied with each drill rig:

- operator's instructions;
- maintenance instructions;
- spare parts list;
- transport and assembly instructions, where applicable.

The operator's instructions shall be available on the machine, in a place specially provided for them.

This standard specifies only safety related matters in those instructions.

The instructions are part of the product and are important documents for the safe and proper operation, maintenance and service of the drill rigs. The text shall be simple, adequate and complete. The wording shall be adapted to the people who are using the products. The information shall be comprehensive and explicit.

All information concerning personal safety shall be printed in a type-face conspicuously deviating from the rest of the text.

NOTE For guidance see ISO 6750:1984.

### 7.4.2 Operator's instructions

The operator's instructions shall inform the operator how to use the machine. All instructions which are important for the safe operation of the machine shall be included.

The operator's instructions shall on their first page and/or front cover give the following information:

- title of instruction;
- type designation of drill rig concerned together with information on type, model and serial number if applicable;
- name and full address of manufacturer and the sales company, distributor or authorized agent.

The operator's instructions shall contain at least the following information and instructions for the safe use of the drill rig:

- the same information as on the data plate;
- names and addresses or a reference to a list of authorized repair and service agents;
- specification of the intended use of the machine;
- complete instructions for the operation of the machine;
- a list of ways, which as shown by experience are applied, in which the drill rig shall not be used and other foreseeable misuse;
- a description of the operator's controls and direction of movements;
- the need to check the emergency stops and trip devices for their proper function before start of each shift and after tramming;
- full information on matters of stability so as to enable proper parking, driving and operation of the drill rig. Maximum allowed gradient angle shall be stated for parking, drilling and tramming conditions;

- define the minimum wind speed, which makes it necessary to stop drilling and put the drill rig in parking position;
- define the measures which are necessary when the wind force exceeds the value allowed for parked and out of service condition;
- limitation of conditions for tramping shall be given if necessary;
- the highest gradient allowed for the drill rig with retained stability margins when tramping on slopes;
- explanation of symbols used;
- a general view of the drill rig and its attachments;
- necessary drawings, diagrams and illustrations of sufficient size to be quite clear showing the designation of major components, their functions, locations and relationships with the whole drill rig;
- a load/speed diagram for the winches and draw-works;
- maximum ground pressure occurring under working conditions;
- special warnings against actions which can cause injuries to the operator or other personnel;
- instruction for operating drill rigs in confined conditions so that the exhaust gases shall be directed in such a way that they do not return to the working area and create a hazard;
- information about the required no access area for a remotely controlled and/or unmanned, automatically operated drill rig;
- information about the safe area from which the operator can control the drill rig with the remote control box, e.g. safety distance between the operator and the drill rig;
- information about residual hazards that may occur due to insufficiency of the protection system, e.g. the need of cleaning the auger;
- instructions on the use of safety harnesses and escape equipment;
- safety precautions to be taken when transporting, assembling and dismantling the drill rig, parts and attachments with particular attention to the erection and securing of drilling masts, derricks and feed beams;
- the location and use of fire extinguishers;
- limits of ambient temperatures for which the drill rig is designed;

- the A-weighted sound pressure level at the operator's position if exceeding 70 dB, measured as specified in Annex A. Should the sound pressure level not exceed 70 dB, this fact shall be indicated;
- the A-weighted continuous sound power level emitted by the machine as measured in accordance with Annex A if the A-weighted sound pressure level at any workstation exceeds 85 dB;
- the weighted root mean square acceleration value to which the body (feet or posterior) is subjected, measured according to Annex A, if it exceeds  $0,5 \text{ m/s}^2$ ; should it not exceed  $0,5 \text{ m/s}^2$  this shall be mentioned.

NOTE See EN 292-2:1991, Annex A.

#### **7.4.3 Special safety instructions in the operator's instructions**

In order to ensure a satisfactory safety level the following safety instructions shall be given in a separate clause:

- it shall be made fully clear to the operator where the major risks are and what measures he shall take to make the operation safe;
- pictures showing the danger zones of the drill rig both during drilling and tramping;
- instructions shall be given how to replace safely drill rods/pipes with the help of the rotation mechanism and other auxiliary means which are available;
- instructions shall be given on how the emergency stops and trip devices according to 5.4.2 are installed and function;
- the need to check the emergency stops and trip devices for their proper function before start of each shift and after tramping;
- the instructions shall specify that the operators shall be given practical training in the operation of the drill rig with special emphasis on the above safety precautions;
- instructions for the use of equipment for monitoring the ambient atmospheric conditions when working in a confined space;
- instructions and information on modular assembly and disassembly of the drill rig;
- instructions to remove ice under sub-zero temperature conditions.

#### **7.4.4 Maintenance instructions**

The maintenance instructions shall at least contain:

- the same identification as for the operator's instructions;
- names and addresses or a reference to a list of authorized repair and service agents;

- daily, weekly and other scheduled maintenance intervals;
- specification of hydraulic fluid;
- instructions on the maintenance of fire extinguishers;
- instructions for the safe assembly and disassembly of parts which are heavy or in other ways difficult to handle;
- information about measuring points and/or locations of diagnostic fault finding equipment and they shall be clearly marked in pictures and tables;
- drawings/functional diagrams for electric, hydraulic and pneumatic circuits. Illustrations shall be of sufficient size to be clear and show the designation of major components, their functions, locations and relationships in the whole drill rig;
- instructions for frequency of checking and for replacement of parts which are classified by the manufacturer to be of particular importance for safety. Methods to check the wear of such parts shall be given;
- instructions for the maintenance/examination of wire ropes, winches and travelling block, see Annex B;
- special warnings against actions which can cause injuries to the repairer or other personnel.

#### **7.4.5 *Special safety instructions in the maintenance instruction***

In order to ensure a satisfactory safety level the following safety instructions shall be given in a separate clause.

When there is a need for an operator or a helper to work on the rig in the working area or danger zone and this involves activation of one or several machine functions such work shall only be done under the following conditions:

- there shall always be two people present, both being fully instructed on the safety issues. One of them shall supervise, from the main operator's position, the safety of the service man doing the work;
- the supervisor shall have immediate access to an emergency stop in all situations;
- the area where the service work is to be carried out shall be properly illuminated;
- communication between the service man and the supervisor at the main operator's position shall be established in a reliable manner;
- only when the drill rig is shut down completely and the means of starting are isolated is a person allowed to perform repair and maintenance work alone on the drill rig.

#### **7.4.6 *Spare parts list***

The spare parts list shall contain all relevant spare parts with unambiguous identification and information on the location of the part in the drill rig.

## **Annex A (normative)**

### **Measurement of noise and vibration**

#### **A.1 General**

Both noise emission from, and vibration on, a drill rig are generated by the machine itself and to a large extent also by the process. Both noise and vibration may vary with the type of ground or rock in which the drill rig is operating. For a type test only a controlled operation can be used so that repeatability can be achieved.

For rotary drill rigs therefore, the influence of the process is eliminated by letting the drill rig work at full speed but without the drilling tool engaged. For percussive drill rigs the major source of noise and vibration is the percussive drill itself and the drill steel and therefore the drill rig shall drill in rock or a concrete block at rated power.

The noise test shall be carried out under free field conditions over a reflecting plane and the sound power level shall be measured in accordance with ISO 4872:1978. When testing in compliance with ISO 4872:1978 the instrumentation shall be in accordance with IEC 651:1979 and IEC 804:1985.

Measurement of the noise at the operator's position shall be made in accordance with ISO/DIS 11201:1993.

Measurement time shall not be less than 15 s.

As the drill rigs are stationary during drilling and there is no need for the operator to permanently hold on to any single control lever, the exposure of the hand arm system to vibration is not relevant.

#### **A.2 Operation of the drill rig during noise and vibration tests**

##### **A.2.1 Rotary drill rigs**

During the noise emission and vibration tests the rotary drill rig shall be operated under no load in a normal operational cycle. All motors and engines shall be run at rated speed and auxiliary equipment, such as cooling fans etc. shall be run at maximum speed. The "in-the-hole tool" shall be attached to the rotary head. Separate tramming engines on the drill rig shall not be in operation during the noise and vibration test.

##### **A.2.2 Rotary-percussive drill rigs**

During the noise emission and vibration tests the rotary-percussive drill rig shall be operated in a normal operating cycle and at rated performance level. Drilling shall be performed in rock or in a concrete block and the drill bit shall be drilled at least 0,1 m into the rock or concrete before the measurement starts. All motors and engines shall be run at rated speed and auxiliary equipment, such as cooling fans, shall be run at maximum speed. Separate tramming engines on the drill rig shall not be in operation during the test.

#### **A.3 Measurement of the sound power emission**

The measurement shall be made in compliance with ISO 4872:1978. When using a hemispherical measurement surface a minimum of 6 microphone positions (2, 4, 6, 8, 10 and 12) shall be used in accordance with 7.2.3, alternative B, of ISO 4872:1978.

The radius of the hemisphere to be used in the measurement shall be determined by the basic length of the drill rig. The radius shall be:

- 4 m when the basic length of the drill rig to be tested is not greater than 1,5 m;
- 10 m when the basic length of the drill rig to be tested is greater than 1,5 m but not greater than 4 m;
- 16 m when the basic length of the drill rig to be tested is greater than 4 m.

If a parallelepipedal measurement surface is used a minimum of 9 microphone positions (1, 2, 3, 4, 5, 6, 7, 8 and 9) shall be used in accordance with 7.3 of ISO 4872:1978.

Non sound emitting parts of the drill rig may be accepted outside the reference surface but the drill head(s) shall always be included within the reference surface in accordance with 7.2.1 of ISO 4872:1978.

#### **A.4 Measurement of noise at the operator's position**

##### **A.4.1 General**

The continuous sound pressure level at the operator's position shall be measured and the level in A-weighted mean value shall be given in the operator's instructions if the value exceeds 70 dB(A). If less than 70dB(A), this fact shall be stated.

**A.4.2 Performance of test**

The test shall be carried out and the results shall be reported in accordance with ISO/DIS 11201:1993 with amendments as listed below:

- the drill rig shall be operated in accordance with **A.1** and **A.2**;
- the cab shall have windows and doors closed during test. Ventilation equipment, if available, shall be in operation at maximum speed;
- the microphone shall be located in accordance with clause **11** of ISO/DIS 11201:1993.

**A.5 Results of noise measurements**

The sound power level shall be reported in accordance with clause **10** of ISO 4872:1978.

The sound pressure level at the operator's position shall be reported in accordance with clause **13** of ISO/DIS 11201:1993.

In the test reports referred to, the rated power of the drill rig shall be stated and the number and type of drill heads/rock drills shall be stated additionally.

**A.6 Vibration test**

The operating conditions shall be as stated in **A.2**.

The vibration shall be measured for an operator either sitting or standing as foreseen by the manufacturer at the operator's workplace. The vibration shall be measured in accordance with ISO 2631-1:1985 and in all three directions, *x*, *y* and *z*. The vibration value shall be stated as the geometric sum of the weighted mean values in the three directions calculated in accordance with **4.3** of ISO 2631-1:1985.

**Annex B (normative)****Instructions for the examination and checking of blocks, wire ropes and chains****B.1 Instructions for the examination and maintenance of travelling blocks and wire ropes**

Wire ropes used in drilling operations become unusable because of wear and wire breakage and shall be discarded according to certain criteria. The code of practice for examination and discard of wire ropes given in ISO 4309:1990 shall be followed.

The winch ropes, including their anchorages, and the other load-carrying components of the travelling block and winch system e.g. sheave bearings, rope sheaves and drill hooks shall be checked at least once a week.

Wire ropes shall be discarded in accordance with **3.5** of ISO 4309:1990. In the table in **3.5** of ISO 4309:1990, classification groups M1 and M2 shall be used.

On drill rigs with normal hook loads of more than 1 000 kN, the draw-works or winch rope shall be regularly paid out and shortened according to a plan laid down by the manufacturer on basis of experience and relevant working conditions.

Before work is carried out, in which the normal hook load is to be exceeded, the draw-works or winch rope shall be examined. The work may only be carried out if the rope is free from any defect which influences the load-carrying capacity.

**B.2 Instructions for the checking of roller and leaf chains**

Roller and leaf chains used as part of the feed system become unusable because of stretch and wear.

They shall be checked daily for signs of wear or corrosion. Tension shall be checked daily.

Chains shall be checked weekly for stretch and once the "pitch length" or total length has been increased by 2 % it shall be discarded.

**Annex C (normative)****Brake test for drill rigs excluding truck and tractor mounted drill rigs****C.1 Test conditions****C.1.1 The following values shall be measured:**

- the retardation of the drill rig to ensure compliance with clause **5.6.3** and **5.6.4**;
- the maximum force applied to the brake control to achieve the desired brake force;

— the pulling force for brake test, where applicable.

**C.1.2** Where possible the engine shall be disengaged from the transmission in the brake test and where this is not possible the highest gear consistent with the test speed shall be selected.

In the case a hydrostatic transmission braking system is used, the transmission circuit shall be bypassed when testing the secondary brake system.

**C.1.3** The test speed shall be the maximum achievable speed on a level surface.

**C.1.4** The test course shall consist of a hard, dry surface with a well compacted base. Ground moisture may be present to the extent that it does not adversely affect the braking test. The test course shall not have a slope more than 3 % at right angles to the direction of travel.

**C.1.5** Test shall be performed with maximum drill rig mass and under moving conditions as specified by the manufacturer.

**C.1.6** All parameters relating to the brake system, e.g. tyre size, brake adjustment and pressures in the brake system etc. shall be as specified by the manufacturer of the drill rig. No manual adjustments shall be made to the braking system during any single performance test.

**C.1.7** All brake tests shall be performed with burnished (conditioned) brakes. The burnishing procedure shall be checked by consulting the brake manufacturer.

**C.1.8** Immediately prior to a test, the drill rig shall be operated until the fluids, e.g. engine and transmission oils, are at normal temperature.

## **C.2 Performance of the tests**

**C.2.1** The forces applied to the brake system controls in order to achieve the maximum brake forces shall be measured and shall not exceed the values stated in 8.1.1, Table 2 of ISO 3450:1985.

**C.2.2** For the test on brake systems using stored energy, a test point is required in the brake line near the brakes to enable actuating pressure to be monitored.

The service brake energy reservoir shall be fully charged and the power source then made inoperative. Five full service brake applications shall be made with the machine stationary and the brake actuating pressure noted at the end of the fifth application.

The drill rig shall then undergo a dynamic service brake test, see **C.2.3**. The drill rig shall be operated at the test speed and the driver shall control the service brake pressure to the value noted after the fifth test above. The performance of the service brake in this test shall comply with the requirements of **5.6.3**. Where a warning device is provided, it shall be tested in accordance with **8.4** of ISO 3450:1985.

### **C.2.3 Dynamic tests for wheel mounted drill rigs**

All dynamic tests shall be performed with cold brakes as defined in **4.10** of ISO 3450:1985. Additionally, totally enclosed brakes, including oil-immersed brakes, shall be considered cold if the temperature measured on the out-side of the housing, closest to the brake, is below 50 °C or within the value specified by the manufacturer.

#### **C.2.3.1 Service brake test**

The maximum brake force shall be determined as the minimum result of a test series of at least four individual tests. In the case of drill rigs designed for normal operation in either direction there shall be at least two individual tests in each direction. In this case the requirements of **5.6.3** shall be met for both directions.

#### **C.2.3.2 Heat fade test**

The service brakes shall be applied and released for seven consecutive stops at or as near as possible to maximum retardation of the drill rig without skidding. After each stop, the initial test speed shall be regained as quickly as possible using maximum acceleration. An eighth stop shall be made with measured retardation. The brake force shall not be lower than the minimum value measured in the test described in **C.2.3.1**.

#### **C.2.4 Secondary brake test**

Tests to determine the brake force shall be as described for the service brake in **C.2.3** and the performance shall comply with **5.6.4** and **C.2.3.1**.

### C.2.5 Parking brake test

Where the parking brake is separate from the secondary brake it shall be subjected to either:

- a static gradient test; or
- a pull test.

In the gradient test the drill rig shall be positioned on a slope 1,2 times the maximum gradient on which it is designed to operate (e.g. if the maximum operating gradient is 20 %, the test gradient shall be 24 %). The brake shall be applied and shall hold the drill rig stationary. The test gradient may be either a roadway or a tilt platform with skid-resistant surface.

In the pull test a pulling force shall be applied to the drill rig and the parking brake shall be applied. The transmission shall be in a neutral position. The test course shall not have a slope more than 1 % in the direction of travel.

The pulling force,  $F$ , shall be applied horizontally near the ground and be at least equal to:

$$F = \frac{1,2MgS}{100}$$

where

- $F$  is the pulling force in N;
- $M$  is the maximum mass of the drill rig in kg;
- $g$  is the acceleration due to gravity in  $m/s^2$ ;
- $S$  is the maximum gradient on which the drill rig is designed to operate, expressed as a percentage.

### C.2.6 Test report

The test report shall be drawn up in the format of clause 9 of ISO 3450:1985 where appropriate.

## Annex D (normative)

### Hazards related to operation modes of drill rigs

Hazards can primarily occur under the following operating modes:

- a) transportation to and from job site;
- b) rigging and dismantling on job site;
- c) drilling and maintenance on job site;
- d) tramming between drilling positions on job site;
- e) out of service on job site;
- f) storage at plant depot, or job site;

Type of hazards	Operating modes					
	a	b	c	d	e	f
1 Drill rig tipping, sliding	×	×	×	×	×	
2 Leakage of oil, fuel, coolant, hydraulic fluid	×	×	×	×	×	×
3 Accidental fall of drilling accessories	×	×	×	×		
4 Ejection of rubble off the tool			×	×		
5 Loss of hydraulic and pneumatic pressure	×	×	×	×	×	
6 Electric shock, contact with:						
6.1 overhead power line;	×	×	×	×		
6.2 underground service line;			×			
6.3 accidental exposure to live parts of equipment.		×	×	×	×	
7 Mechanical failures or malfunction of components		×	×	×	×	
8 Unprotected moving parts of equipment		×	×	×		

9	Exposure to cold or hot components		×	×	×		
10	Whipping of ropes and hoses		×	×	×		
11	High pressure fluids and gases		×	×	×	×	
12	Excessive vibrations transmitted to personnel			×			
13	Inadequately guarded accesses and positions		×	×	×		
14	Accesses and positions rendered slippery		×	×	×		
15	Excessive noise exposure		×	×	×		
16	Deteriorated working environment:						
16.1	Weather (e.g. rain, storm, ice)	×	×	×	×	×	×
16.2	Working ground (e.g. mud, silt)	×	×	×	×		
17	Uncontrolled slewing or moving of the rig		×	×	×		
18	Exposure to unhealthy concentrations of dust and toxic gases			×	×		
19	Risks during erection and dismantling of masts and feed beams		×				
20	Fire	×	×	×	×	×	×
21	Inadequate lighting	×	×	×	×		
22	Falls of persons from elevated positions		×	×	×	×	×
23	Exposure to battery electrolyte	×	×	×	×	×	
24	Explosion		×	×	×		

## Annex E (informative) Symbols and signs

### E.1 Introduction

This annex gives a collection of symbols to be used to promote the safe use and operation of drill rigs. The symbols are taken from ISO 7000:1989 *Graphical symbols for use on equipment — Index and synopsis*, ISO 6405-1:1991 *Earth-moving machinery — Symbols for operator controls and other displays — Part 1: Common symbols*, ISO 6405-2:1993 *Earth-moving machinery — Symbols for operator controls and other displays — Part 2: Specific symbols for machines, equipment and accessories* and EN 61310-1:1995 *Safety of machinery — Indicating, marking and actuating principles — Part 1: Visual, audible and tactile signals*, however some symbols included are specific to drill rigs.

This annex is divided in parts, the first one containing general symbols regarding warning of hazards to safety and health, followed by parts containing symbols for control and operation in general, for engines, hydraulic and pneumatic systems and drilling operations specifically.





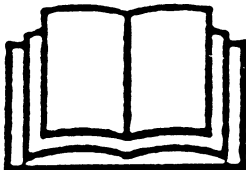

The symbols given are basic symbols for a single function but several symbols can be combined to symbolize a more complex function and some examples are given for such combinations which are common in operation of drill rigs.



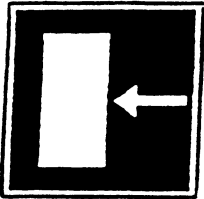



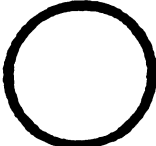
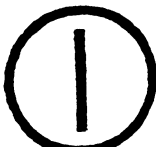

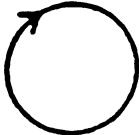

In this annex the carrier part of the machine is symbolized by a triangle or a block which may be replaced in the actual case by a symbol picturing the carrier configuration.



### E.2 General safety and warning signs

Symbol	Symbol application	Remark
	Read the operator's instructions	ISO 7000:1989 0419
	Mandatory on all drill rigs Symbol white, Background blue	





	<p>Ear protection shall be worn</p> <p>Symbol white, Background blue</p>	<p>EN 61310-1:1995 ISO 3864:1984</p>
	<p>Safety harness shall be worn</p> <p>Symbol white, Background blue</p>	<p>EN 61310-1:1995 ISO 3864:1984</p>
	<p>Safety helmet shall be worn</p> <p>Symbol white, Background blue</p>	<p>EN 61310-1:1995 ISO 3864:1984</p>
	<p>Foot protection shall be worn</p> <p>Symbol white, Background blue</p>	<p>EN 61310-1:1995 ISO 3864:1984</p>
	<p>Hand protection shall be worn</p> <p>Symbol white, Background blue</p>	<p>EN 61310-1:1995 ISO 3864:1984</p>
	<p>Respirator equipment shall be worn</p> <p>Symbol white, Background blue</p>	<p>EN 61310-1:1995 ISO 3864:1984</p>
	<p>General warning caution, risk of danger</p> <p>Background yellow Symbol and triangular band black</p>	<p>EN 61310-1:1995 ISO 3864:1984 ISO 7000:1989 0434</p>

	<p>Caution, risk of electric shock</p> <p>EN 61310-1:1995 ISO 3864:1984</p> <p>Background yellow Symbol and triangular band black</p>	
	<p>Emergency exit</p> <p>EN 61310-1:1995 ISO 3864:1984</p> <p>Background colour green, symbol white</p>	
	<p>No access for unauthorized persons</p> <p>EN 61310-1:1995 ISO 3864:1984</p> <p>Background colour white, symbol black and circular band and crossbar red</p>	
	<p>Risk for squeezing</p> <p>Background yellow Sign and triangular frame black</p>	
<p><b>E.3 General control symbols</b></p>		
<p>NOTE All symbols are black unless otherwise stated.</p>		
	<p>On/start</p>	<p>ISO 6405-1:1991 IEC 417 5007</p>
	<p>Off/stop</p>	<p>ISO 6405-1:1991 IEC 417 5008</p>
	<p>On and off</p>	<p>ISO 6405-1:1991 IEC 417 5010</p>
	<p>Emergency stop actuator</p> <p>Colour red, Mushroom type push-button</p>	<p>as specified in EN 418:1992</p>

	<p>Combined stop and emergency stop device</p> <p>Colour red, symbol white. Mushroom type push button</p>	
	<p>Rotation</p> <p>Colour black</p>	<p>ISO 7000:1989 0258</p>
	<p>Continuously variable — linear</p>	<p>ISO 6405-1:1991 7.12 IEC 417 5004</p>
	<p>Continuously variable — Rotational</p>	<p>ISO 6405-1:1991 7.13 ISO 7000:1989 1364</p>
	<p>Speed</p>	<p>IEC 417 5124; 5107; 5108</p>
<p>Linear Rotation</p>		
	<p>Slow</p>	
	<p>Normal</p>	
	<p>Fast</p>	
	<p>Locked function</p>	<p>ISO 7000:1989 0018; 0019</p>
	<p>Unlocked function</p>	
	<p>Direction of movement</p>	<p>ISO 6405-1:1991 717; 7.18</p>
	<p>The dashed square to be replaced by a symbolic sketch of affected machine</p>	
	<p>Pressure (to be used where the medium under pressure is not specified)</p>	<p>ISO 6405-1:1991 6.9 ISO 7000:1989 1701</p>

	Oil pressure	Combined symbol
	Remote control	ISO 7000:1989 0093
	Automatic cycle	ISO 7000:1989 0026

**E.4 Symbols for information**

	Lift point	ISO 6405-1:1991 7.25
	Stability limit	
	longitudinal angle	
	transverse angle	
The block may be replaced by a symbol picturing a wheel mounted or a crawler mounted drill rig		









**E.5 Symbols to be used for the control of the engine, fuel, brake transmission systems and hydraulic system**

For drill rigs symbols from ISO 6405-1:1991 for the control of the following functions should be chosen as follows:



basic symbol shapes	in accordance with clause <b>6</b>
general symbols	in accordance with clause <b>7</b>
engine	in accordance with clause <b>8</b>
transmission	in accordance with clause <b>9</b>
hydraulic system	in accordance with clause <b>10</b>
brakes	in accordance with clause <b>11</b>
fuel system	in accordance with clause <b>12</b>
light systems	in accordance with clause <b>13</b>
window	in accordance with clause <b>14</b>
climate system	in accordance with clause <b>15</b>
seat	in accordance with clause <b>16</b>

**E.6 Symbols to be used for the control of the drilling operation**

E.6.1 *General symbols*

	Pneumatic energy (Compressed air)	ISO 7000:1989 0231
 Full                  Reduced	Compressed air flushing	Pneurop
 Full                  Reduced	Air flushing with oil	Combined symbol
 Full                  Reduced	Fluid flushing	Pneurop
	Air pressure	Combined symbol
	Water pressure	Combined symbol
	Oscillation	ISO 7000:1989 0007; 0008
	Limited rotation and return	
	Oscillating rotary movement (continuous)	

E.6.2 *Symbols for general machine functions*

	Clutch	ISO 6405-1:1991 9.7 ISO 7000:1989 1308
 Engaged                  Disengaged	Brake	ISO 7000:1989 0020; 0021

	Centrifugal pump	ISO 7000:1989 0135
	Piston pump	
Example	Pump function symbols	
	× = G for grout pumps × = C for cement pumps × = M for mud pumps	
	Centrifugal pump, pressure	Combined symbol
	Feed	ISO 7000:1989 0259; 0262
	Feed pressure	Combined symbol
	Feed force	Combined symbol
	Float	
	Percussion	
Full power	Reduced power	
	Percussion pressure	Combined symbol

		Stabilizing jack	ISO 6405-2:1993 7.2; 7.6
Left beam out	Left jack down		

**E.6.3 Rodhandling system**

	Rod coupling and uncoupling				
	Clamp				
	Opening				
	Closing				
	Opening		Closing	Retaining flaps	
	Retaining spanner				
	Chuck/Break-out table Rotation arrow for breaking	Combined symbol			
	Rod handling magazine, combined with rotation symbol				



Rod handling arm moving from magazine to drill centre



Rod handling arm moving from drill centre to magazine

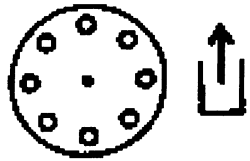

Rod handling magazine for vertical movement of rods

Rod gripper



Closing



Opening

**E.6.4 Mast erection and positioning**



Mast raising and lowering respectively



Mast displacement/crowd, combined with direction arrows

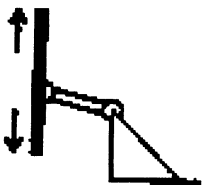

Feed beam extension

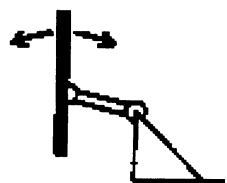

Feed beam dump



Feed beam swing

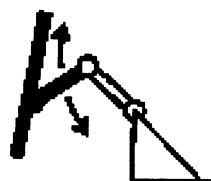

Boom extension, folding boom

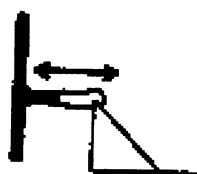

Boom extension, telescopic boom

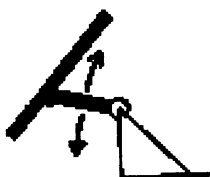

Boom lift



Boom swing



Feed beam rollover

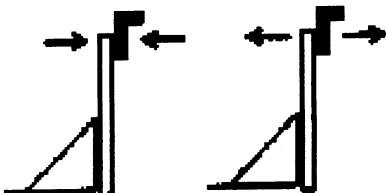

Mast extension, locking and unlocking

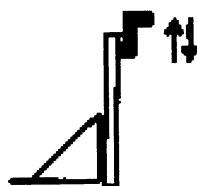

Mast extension, up and down

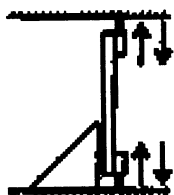

Feed beam support, up and down

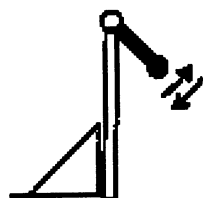

Folding mast



Mast inclination, sideways

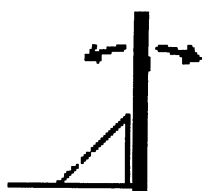

Mast inclination, front — rear



Mast movement, parallel movement



Power swivel tilt



Power swivel swing out



Sliding power swivel

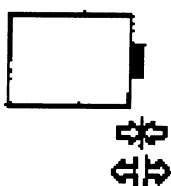

Power swivel, locking and unlocking

E.6.5 Winch and slip rope drum

	<p>Winch — Basic symbol</p>	<p>ISO 6405-2:1993 18.1 ISO 7000:1989 1176</p>
	<p>Winch — Brake engaged</p>	<p>Combined symbol</p>
	<p>Winch — Spool out</p>	<p>ISO 6405-2:1993 18.2</p>
	<p>Winch — Free spool</p>	<p>ISO 6405-2:1993 18.4 ISO 7000:1989 1540</p>
	<p>Cable tool winch (free fall)</p>	<p>Combined symbol</p>
	<p>Slip rope drum</p>	

E.6.6 Trimming

	<p>Trimming of crawlers, forward or reverse</p>	<p>Pneurop</p>
	<p>Trimming of wheel mounted rigs, forward or reverse</p>	

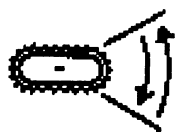

Track oscillation

**E.7 Miscellaneous symbols**



Mixer

ISO 7000:1989  
0131



Auger cleaner



Core extruder



Casing oscillator or rotator

Combined symbol



Slewing of superstructure



Relative displacement of double drilling  
headsystem



Suction hood, up and down

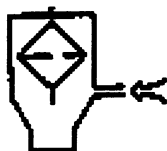

Dust collection

## **Annex F (informative)**

### **Bibliography**

In this bibliography are listed standards and other literature which have a bearing on the specifications of this standard but to which normative reference has not been made.

EN 61310-1:1995, *Safety of machinery — Indicating, marking and actuating principles — Part 1: Visual, audible and tactile signals.*

ISO 3864:1984, *Safety colours and signs.*

ISO 4253:1993, *Agricultural tractors — Operator's seating accommodation — Dimensions.*

ISO 5010:1992, *Earth-moving machinery — Rubber-tyred machines — Steering capability.*

ISO 6405-1:1991, *Earth-moving machinery — Symbols for operator controls and other displays — Part 1: Common symbols.*

ISO 6405-2:1993, *Earth-moving machinery — Symbols for operator controls and other displays — Part 2: Specific symbols for machines, equipment and accessories.*

ISO 6750:1984, *Earth-moving machinery — Operation and maintenance — Format and content of manual.*

ISO 7000:1989, *Graphical symbols for use on equipment — Index and synopsis.*

ISO 7095:1982, *Crawler tractors, crawler loaders — Operator's controls.*



## List of references

See national foreword.

---

# BSI — British Standards Institution

BSI is the independent national body responsible for preparing British Standards. It presents the UK view on standards in Europe and at the international level. It is incorporated by Royal Charter.

## Revisions

British Standards are updated by amendment or revision. Users of British Standards should make sure that they possess the latest amendments or editions.

It is the constant aim of BSI to improve the quality of our products and services. We would be grateful if anyone finding an inaccuracy or ambiguity while using this British Standard would inform the Secretary of the technical committee responsible, the identity of which can be found on the inside front cover. Tel: 020 8996 9000. Fax: 020 8996 7400.

BSI offers members an individual updating service called PLUS which ensures that subscribers automatically receive the latest editions of standards.

## Buying standards

Orders for all BSI, international and foreign standards publications should be addressed to Customer Services. Tel: 020 8996 9001. Fax: 020 8996 7001.

In response to orders for international standards, it is BSI policy to supply the BSI implementation of those that have been published as British Standards, unless otherwise requested.

## Information on standards

BSI provides a wide range of information on national, European and international standards through its Library and its Technical Help to Exporters Service. Various BSI electronic information services are also available which give details on all its products and services. Contact the Information Centre. Tel: 020 8996 7111. Fax: 020 8996 7048.

Subscribing members of BSI are kept up to date with standards developments and receive substantial discounts on the purchase price of standards. For details of these and other benefits contact Membership Administration. Tel: 020 8996 7002. Fax: 020 8996 7001.

## Copyright

Copyright subsists in all BSI publications. BSI also holds the copyright, in the UK, of the publications of the international standardization bodies. Except as permitted under the Copyright, Designs and Patents Act 1988 no extract may be reproduced, stored in a retrieval system or transmitted in any form or by any means – electronic, photocopying, recording or otherwise – without prior written permission from BSI.

This does not preclude the free use, in the course of implementing the standard, of necessary details such as symbols, and size, type or grade designations. If these details are to be used for any other purpose than implementation then the prior written permission of BSI must be obtained.

If permission is granted, the terms may include royalty payments or a licensing agreement. Details and advice can be obtained from the Copyright Manager. Tel: 020 8996 7070.